

PRODUCT BROCHURE

The ultimate guide to aluminium gutters and downpipes systems; fascia, soffit and coping; and drainage outlets.

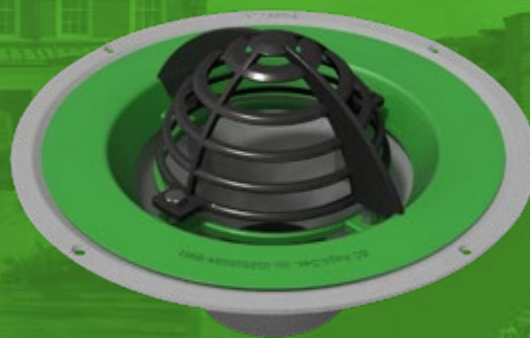
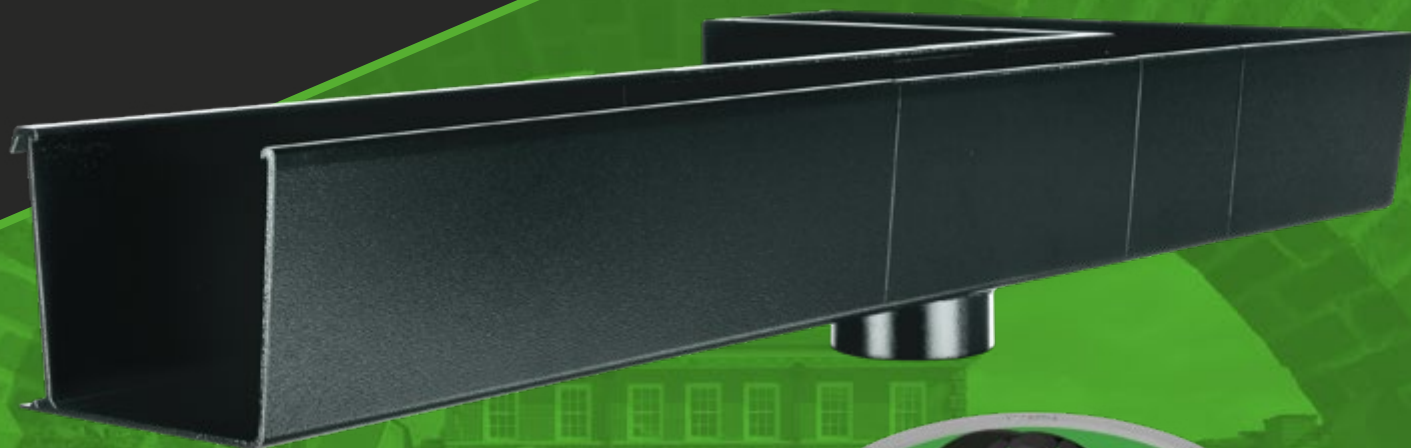

Contents

About Aliaxis	03
About Alutec	04
Market Sectors	05
Why Aluminium?	06
Colour Options	07
Rainwater Solutions - Gutter Systems	08
Gutter System Profiles	09
Gutter / Downpipe Selector Chart	10
Evolve Gutter Profiles Overview	11
Evolve Gutter Case Studies	12
Traditional Gutter Profiles Overview	18
Traditional Gutter Case Studies	19
Aligator Gutter Profiles Overview	25
Aligator Gutter Case Studies	26
Rainwater Solutions - Downpipe Systems	32
Rainwater Solutions - Hopper Heads	33
Downpipe and Hopper Case Studies	34
Eaves Solutions - Fascia and Soffit	38
Evoke Fascia and Soffit Case Studies	39
Eaves Solutions - Coping	45
Evoke Coping Case Studies	46
Drainage Solutions - Outlets	48
Elite Outlets Case Studies	49
Rainwater Solutions - Technical Information	51
Gutters Flow Capacity	54
Hopper Heads Flow Capacity	56
Eaves Solutions - Technical Information	57
Drainage Solutions - Technical Information	60
General Information	62
Online Calculators and Tools	65
Notes	66
Contacts	67

About Aliaxis

Aliaxis is a global leader in advanced piping systems for building, infrastructure, industrial and agriculture applications.

We provide communities around the world with sustainable innovative solutions for water and energy, leading the industry in a way that anticipates the rapidly evolving needs of its customers and of society.



With a global workforce of over 14,000 employees, Aliaxis offers specific solutions that meet our customers' most demanding needs across the globe.

We are operating in over 40 countries, combining local solutions with global innovation and operational excellence. Aliaxis is privately owned, with its global headquarters in Brussels, Belgium.

ALIAXIS IN THE UK

We are experts in fluid management solutions.

We are passionate about creating sustainable systems for water, gas and energy, leading our industry in a way that anticipates the rapidly evolving needs of our customers, ensuring peace of mind for future generations.

Our innovative portfolio of fluid management solutions for building services, infrastructure networks and industrial applications include ranges from the brands you know and love, such as: Alutec, Durapipe, GPS, Hunter Plastics, Marley Plumbing and Drainage, Multikwik, and Philmac.



About Alutec

Alutec is the UK leader in innovative aluminium guttering, rainwater drainage and eaves solutions. Providing a complete service and product solution tailored to the needs of each project, we offer the most sustainable, durable and high-performance systems on the market.

THE ENVIRONMENT AND OUR RESPONSIBILITY

Alutec is committed to being a responsible company in every aspect of our operations.

Our guiding principles:

- We manage our business with professionalism and integrity
- We are committed to full legal compliance in all that we do
- We aim to provide a safe, fulfilling and rewarding environment for our people
- We benchmark and evaluate what we do to continually improve our value proposition
- We actively measure and manage the environmental impacts of our operation

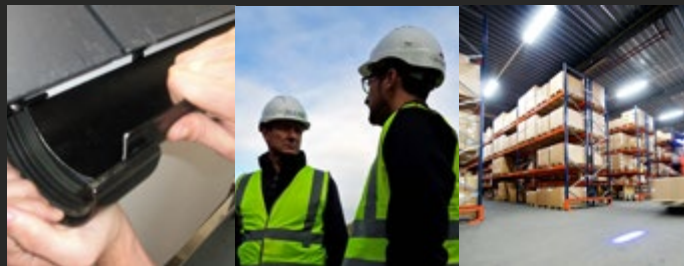

TECHNICAL SUPPORT

Our Technical Services team has many years of experience in all aspects of eaves and roof drainage design for both modern and traditional building methods.

We can assist with:

- Correct system choice
- Roof drainage design calculations
- Installation advice
- Bespoke design service

SALES SUPPORT

Our dedicated Nationwide external sales team backed up by internal sales support is on hand to help with any product or project enquiry you might have.

- Local on-site advice and take-offs
- Fully itemised estimates
- Scheduling quantities
- Developing sales leads
- Staff training

CUSTOMER SUPPORT

Alutec's comprehensive offering is geared towards supporting customers at all stages of the supply chain.

- Delivery on time to the designated site
- Short lead times, most products are on 2 days delivery
- Marketing support
- Advice on storage and maintenance



ONLINE CALCULATORS

Go to www.marleyalutec.co.uk/calculators to take advantage of our innovative online calculators.

- Estimating tool – Produce instant list value estimates for all your Alutec product requirements
- Rainwater drainage design tool – Ensure your pitched and flat roof projects are in full compliance with the rainwater drainage design standard (BS EN12056)
- Specification manager – Produce specification documents based on Alutec's wide range of innovative aluminium rainwater products and eaves solutions

CPD SEMINAR



With so many years of experience and industry knowledge, Alutec offers this RIBA Accredited CPD seminar which will be worth double points to RIBA Chartered Architects.

To book or find out more information please visit our website www.marleyalutec.co.uk

- Learn more about the benefits, sustainability and durability of aluminium for eaves solutions
- It covers the required topics under RIBA's core curriculum
- Delivered online or face-to-face
- Interactive – opportunity to ask questions and discuss specific projects

STANDARDS

All Alutec systems are manufactured to and in excess of the appropriate BS or EN Standards.



ENVIRONMENTAL

Alutec is committed to continually reducing its environmental impact and is accredited to ISO 14001:2015.

PRODUCT AVAILABILITY

Our products are available through all major national and regional building, plumbing and roofing merchants, where you will be able to obtain discounts from the list price. Many of our products are delivered in just 2 days to the designated sites.

ONLINE RESOURCES

We have invested in a high-performance, customer friendly and interactive website where the latest price list, literature, product datasheets and specifications, installation details, BIM files and many others can be downloaded. Please visit <https://www.marleyalutec.co.uk/resources/>.

Market Sectors

Alutec with its unique offering of sustainable aluminium rainwater and eaves products operates in a variety of market sectors.





Why Aluminium?

Aluminium - long lasting, low maintenance, sustainable

Made from marine grade aluminium, Alutec's products offer the very best in terms of durability, lasting for many years with minimal maintenance.

THE PROPERTIES OF ALUMINIUM - A SUSTAINABLE MATERIAL

- Low whole life costs compared to other materials
- Infinitely recyclable – 75% of all the aluminium produced since 1888 is still in use today
- Green energy – hydroelectric or geo-thermal power accounts for 60% of processing requirements

LIGHTWEIGHT, STRONG AND LONG-LASTING

Aluminium is a very light metal, about 65% lighter than steel or cast iron. It has a very high strength to weight ratio and excellent corrosion resistance.

Highly corrosion resistant Aluminium naturally generates a protective oxide coating. Should the surface be damaged, the aluminium simply oxidises again to protect itself. Add a polyester powder coating to provide an attractive and durable finish. This contrasts with steel, where galvanising only offers limited protection and cast iron, which requires regular repainting.

INFINITELY RECYCLABLE

When the old Wembley Stadium (built in 1923) was demolished, 96% of the aluminium was recovered for recycling. Aluminium can be recycled again and again without loss of quality. The re-melting of aluminium requires little energy; it saves up to 95% of the energy required for primary aluminium production.

RESPONSIBLE SOURCING

Aluminium is the World's third most abundant element. 97% of all bauxite mines in the World operate rehabilitation projects and two thirds of the employees are from the local community. The amount of electrical energy required to produce aluminium has dropped by 70% since the 1880's and 60% of that electricity is provided from renewable green energy.

Colour Options



All Alutec systems are available with an architectural grade polyester powder coat (PPC) paint finish.

Architectural grade PPC paint finishes are designed for exterior use and maintain their colour and gloss level for longer. Paint's life expectancy is enhanced further by Alutec's choice of aluminium.

We only use the highest quality marine grade aluminium, greatly increasing durability. The colour range includes Heritage Black, which has a textured surface to accurately replicate the appearance of traditional cast iron gutters and downpipes.

STANDARD COLOURS FOR RAINWATER AND COPING SYSTEMS

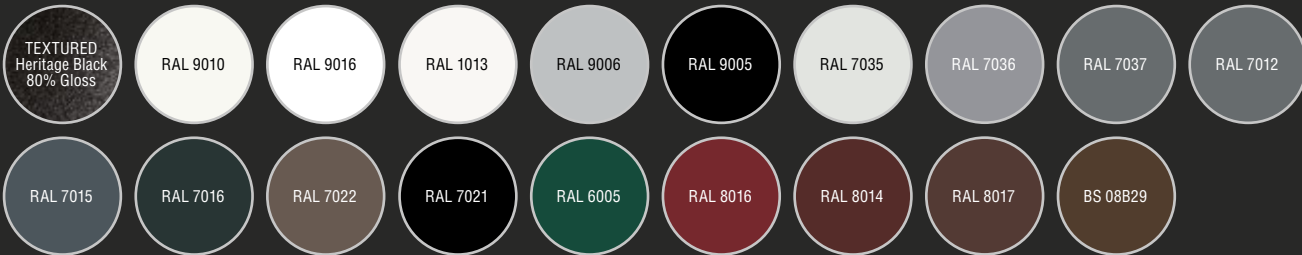

Additional colours, finishes and gloss levels are available, price on application. This chart is a representation of the actual colours, for exact match please ask for sample plates. Mill finish is also available on request.

The standard range of RAL colours are with 30% gloss level (unless otherwise stated).

STANDARD COLOURS FOR FASCIA AND SOFFIT SYSTEMS



PVDF paint system to a 30-40% gloss level.

We are able to supply our Fascia and Soffit in non-standard colours, using aluminium sheet. Please call 01234 321996 for further information or email projects@marleyalutec.co.uk

Rainwater Solutions - Gutter Systems

Alutec's marine grade aluminium gutter systems are available in a wide variety of aesthetics to suit all styles of property, offering functional life expectancy of 50 years or more with minimal maintenance, only periodic aesthetic cleaning required. The colour range is 19 standard colours with architectural grade polyester powder coat (PPC) paint finish, including Heritage Black which has a textured surface to accurately replicate the appearance of traditional cast iron.



evolve

EVOLVE GUTTER SYSTEMS

- Our range of Evolve aluminium guttering systems combine all the benefits of marine grade aluminium with installation as easy as PVC guttering
- Unique patented JuraJoint system for quick, simple and secure jointing
- Evolve Range is available in four distinctive profiles – Half Round, Deepflow, Box and Ogee



traditional

TRADITIONAL GUTTER SYSTEMS

- Manufactured to BS 8530, a complete replica of cast iron gutter systems, ideal for listed buildings and conservation areas
- 65% lighter than equivalent cast iron systems, making it easier and safer to handle and install
- Offering three bolted gutter profiles – Half Round, Victorian Ogee and Moulded Ogee



aligator

ALIGATOR GUTTER SYSTEMS

- Contemporary and sleek solution for modern building design
- Patented Aligator Snap-Fit joint system, proven to reduce installation times by up to 40% compared to traditional bolted systems
- Aligator Classic profile is a domestic size ogee style gutter system with external unions and brackets. The Deepflow, Ogee No.46, Boxer and Giant profiles are with internal joints and concealed brackets.

Gutter System Profiles

A choice of different profiles to suit all types of applications and aesthetic requirements.

GUTTER SYSTEM PROFILE	evolve		traditional		aligator	
Half Round		123x51mm		100mm 113mm 125mm		
Deepflow		128x75mm				130x80mm
Ogee		130x95mm	 Victorian	100mm 113mm 125mm	 Classic	120x75mm
			 Moulded	100mm 125mm 150mm	 No. 46	155x100mm
Box		130x85mm			 Boxer	120x80mm 135x100mm 160x100mm
Giant						200x150mm

Gutter / Downpipe Selector Chart



Use the table below to choose the right gutter and downpipe combination.

				DOWNPIPE SIZE					
				63mm Ø	76mm Ø	102mm Ø	72x72mm	102x76mm	102x102mm
GUTTER SYSTEMS	evolve	Half Round		✓	✓				
		Deepflow			✓				
		Box			✓		✓		
		Ogee			✓		✓		
	traditional	Half Round*		✓	✓	✓	✓	✓	
		Victorian Ogee*		✓	✓		✓	✓	
		Moulded Ogee*		✓	✓	✓	✓	✓	✓
	aligator	Classic		✓	✓		✓		
		Deepflow		✓	✓	✓	✓	✓	✓
		Ogee No. 46		✓	✓	✓	✓	✓	✓
		Boxer*		✓	✓	✓	✓	✓	✓
		Giant			✓	✓	✓	✓	✓

*Compatibility depends on gutter size chosen.

Evolve Gutter Profiles Overview



evolve HALF ROUND

- 123x51mm Half Round aluminium rainwater gutter system
- Flow rate of up to 1.8 l/s and 87m² per downpipe
- Compatible with 63mm downpipes
- Only 2 days lead time for Heritage Black and Anthracite Grey (RAL 7016) products



evolve DEEPFLOW

- 128x75mm Deepflow aluminium rainwater gutter system
- Flow rate of up to 4.9 l/s and 232m² per downpipe
- Compatible with 76mm downpipes
- Only 2 days lead time for Heritage Black and Anthracite Grey (RAL 7016) products

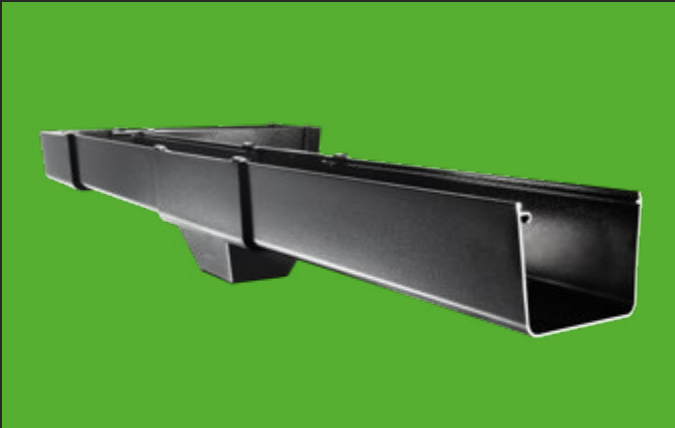

evolve BOX

- 130x85mm Box aluminium rainwater gutter system
- Flow rate of up to 7.0 l/s and 333m² per downpipe
- Compatible with 76mm and 72x72mm downpipes
- Only 2 days lead time for Heritage Black and Anthracite Grey (RAL 7016) products
- Concealed fascia brackets for a sleek and modern aesthetic



evolve OGEE

- 130x95mm Ogee aluminium rainwater gutter system
- Flow rate of up to 7.0 l/s and 333m² per downpipe
- Compatible with 76mm and 72x72mm downpipes
- Only 2 days lead time for Heritage Black
- Concealed fascia brackets for a sleek and modern aesthetic

Urmston Grammar School



Manchester



SNAPSHOT

Urmston Grammar, a selective and independent academy for more than 1000 pupils aged 11 to 18, was founded in the 1920s and its facilities have grown on the present site ever since.

The roof of Urmston Grammar's original main building needed a complete refurbishment due to nail fatigue and the loss of a number of roof slates to the wind. It was decided that during this work, the building's fascia, soffits and guttering would also be replaced to improve the overall look of the building. The previous rainwater system was a combination of dated cast iron and PVC systems, so a unified system and aesthetic was chosen to replace it.

THE SOLUTION

Alutec's Evoke Type B fascia and soffit system was selected in RAL 9010 white colour. The Evolve Ogee gutter system was also installed with 76mm Flushfit downpipes in Heritage Black, a finish which accurately replicates the appearance of cast iron. Both systems are made entirely from marine grade aluminium and are therefore highly corrosion resistant; crucially for a busy school environment, they will never rust or need to be repainted.

AT A GLANCE

Products:

- Evoke type B Fascia and Soffit Systems
- Evolve Ogee Gutter System
- Flushfit 76mm Downpipe System

Colour:



Market sector:

Education

Specifier:

AHR Building Consultancy Ltd.

Contractor:

Allied Roofing (North West) Ltd.

"I had specified Alutec before, so I knew its quality, durability and life span. The aluminium systems provided a high-quality, cost-effective replacement for the old cast iron guttering and aesthetically the building now looks a lot more appealing."

Jamie Wildgoose,
Associate Director of AHR Building Consultancy Ltd.



Social Housing Development



Swansea, Wales



SNAPSHOT

Alutec's aluminium rainwater and eaves products have been used on a high quality modern social housing development in Swansea, Wales.

Consisting of 14 properties, the £1.5 million project embodies the durable, practical and cost-effective ethos so needed within the sector.

Completed by Gwalia, part of the Pobl Group, the development of seven pairs of semi-detached houses in West Glamorgan represents the ideal model of affordable family housing. Designed to blend in with the local architecture and provide dependable performance for the foreseeable future, it was important to achieve a modern aesthetic and choose building products that would stand the test of time.

THE SOLUTION

Installed at the project was Alutec's Evolve half round guttering and Flushfit downpipes, as well as its Evoke fascia and soffits. All of these have a functional life expectancy of 50 years or more and are almost completely maintenance free, reducing life cycle costs and disruption to residents. In addition, Alutec provided water butt fittings to meet the requirements for rainwater harvesting on the development.

AT A GLANCE

Products:

- Evoke Fascia and Soffit Systems
- Evolve Half Round Gutter System
- Flushfit 63mm downpipe System

Colour:



Market sector:

Social Housing

Specifier:

Rio Architects

Client:

Gwalia Housing Association, part of Pobl Group

"We specified the use of Alutec's aluminium products because their durability and style were the perfect match for the design of this project. In the social housing sector, it is particularly important to use products that will not require frequent maintenance and that offer competitive whole life costs."

Andrew Baker,
Director at Rio Architects



Sustainable housing



Northumberland



SNAPSHOT

Valleydale Mews is a shining example of what can be achieved through BIM only construction and the support of expert suppliers with extensive technical knowledge. BIM is essentially a 3D model that provides highly detailed information about every component of a building and allows everyone involved to work from the same coordinated drawings. Alutec was chosen to supply aluminium guttering, fascia and soffits for the project because of its impressive BIM portfolio – the most comprehensive offering of any rainwater product manufacturer.

THE SOLUTION

The small development of four timber-framed, low energy, sustainable dwellings is the flagship project for Space Architecture's latest product: the Spacehus. Taking just four months to complete because of the streamlined process, the properties are fitted with Alutec's long lasting and sustainable Evoke fascia and soffit system as well as its Evolve Half Round guttering and downpipes, all in RAL 7016 anthracite grey colour.

AT A GLANCE

Products:

- Evolve Half Round Gutter System
- Evolve 63mm Downpipe System
- Evoke Fascia and Soffit

Colour:

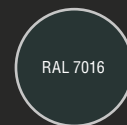

Market sector:

Private Housing

Architect:

Space Architecture

Contractor:

A Douglas Construction

“Choosing Alutec to work on Valleydale Mews was easy, the comprehensive BIM portfolio allowed for a quick and detailed specification process. In particular Alutec's technical department were great to work with: having supplied 2D drawings extracted from our BIM model, Alutec did the rest and we had no need to go back with any amendments. Sustainability and aesthetics were also key requirements for this project, so it was vital that the rainwater and eaves systems delivered on these fronts as well. Alutec's products have impressive performance and sustainability credentials in addition to their contemporary style that fitted perfectly with our build ethos.”

Ryan Wigham,
Architectural Technologist at Space Architecture



A unique new build property



East of Scotland

SHORTLISTED & WINNER
of 'RCI Best Use of a
Rainwater System'



SNAPSHOT

The 500m² self-build property in Angus, Scotland, is owned by David Maxwell, Managing Director of George Martin Builders Ltd and was designed by Fraser Middleton, Director at ARKTX, Chartered Architects. It incorporates four bedrooms, four bathrooms, a curved roofline and even a section of guttering with a positive gradient to accommodate the front entrance, challenging Alutec's systems to adapt to the unusual design.

THE SOLUTION

The design and location of the house presented two main challenges for the rainwater systems: The first challenge was the curved roofline, which was overcome by using a sequence of straight 600mm segments and angles in creating a beautifully seamless sweeping curve. The second challenge was the strength and durability needed from the guttering due to the heavy snowfall commonly experienced in the region. Not only this, but for aesthetic reasons, there were hanging chains from the guttering instead of fitting downpipes, this meant the guttering had to be extra strong to cope with both the weight of a deep snow covering and the hanging chains.

Installed at the dwelling was Alutec's Evolve Deepflow guttering in the Heritage Black colour. The range, made from marine grade aluminium, is very strong and boasts excellent performance and sustainability credentials, having a virtually maintenance free functional life expectancy of 50 years or more and a flow performance rating of 4.9 litres per second, ensuring it can cope with the heaviest of water runoff.

"Building my own home, I was very conscious that I didn't want to compromise on quality and that impact on the environment was kept to a minimum, with this in mind Alutec fitted the brief perfectly."

David Maxwell,
Managing Director of George Martin Builders Ltd



AT A GLANCE

Products:

- Evolve Deepflow Gutter System

Colour:

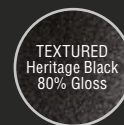

Market sector:

Self-build

Client:

David Maxwell

Contractor:

George Martin Builders Ltd

Architect:

ARKTX

St Catherine's View dementia care home



Winchester



SNAPSHOT

The 56-bedroom development was built by the independent, family run group and took two years to complete. Taking medical best practice into consideration at a design level, the development is made up of five individual house groups as opposed to one large building. The community design enables residents' needs to be met on an individual level, offering a variety of indoor and outdoor environments that provide the right blend of calm and stimulation for each person.

THE SOLUTION

Installed at the site was Alutec's Evolve Deepflow guttering with Flushfit downpipe in grey RAL 7043 colour. Made from marine grade aluminium and using the latest manufacturing technologies, Alutec's rainwater systems have outstanding performance credentials and are one of the most sustainable ranges available in the UK. Aluminium is infinitely recyclable, with an estimated 75% of all aluminium ever produced still in use today.

AT A GLANCE

Products:

- Evolve Deepflow Gutter System
- Flushfit Downpipe System

Colour:

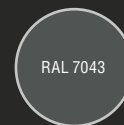

Market sector:

Healthcare

Contractor:

Colten Care Ltd.

Sub-Contractor:

Watertite

"Alutec's aluminium products are virtually maintenance free which was not only appealing from a cost perspective, but it also meant there would be minimal disturbance to the residents of the home, a crucial benefit for our application. PVC and cast iron alternatives could not offer the same benefit, and neither could they offer the right balance of initial cost and lasting value because of either frequent maintenance needs or large material and installation costs."

Harvey Baker,
Purchasing Manager at Colten Care Ltd



Lochside House Hotel



Cumnock, Ayrshire



SNAPSHOT

Winner of the VOWS Awards Scottish Wedding Venue of the Year 2010, the hotel is set in picturesque surroundings overlooking lochs on either side. With such an attractive location, owner Robert Kyle was careful to ensure that all the hotel's external fittings, including the rainwater system, complemented the sophisticated look of the building. Having been recommended Alutec's products for a previous project, he was certain about their reliability and performance and had no hesitation in specifying them again for the extension at Lochside House Hotel.

THE SOLUTION

The Evolve Box gutter system and 72x72mm Traditional downpipe system in Heritage Black colour were specified. The contemporary aluminium box profile, which features concealed top fixing brackets, offers a sleek alternative to the more traditional curved profile, making it perfect for modern building designs, such as Lochside House Hotel. Particularly suitable for projects where a very high capacity is required, the Evolve Box system has a maximum flow rate of seven litres per second, which greatly reduces the number of downpipes required.

AT A GLANCE

Products:

- Evolve Box Gutter System
- Traditional 72x72mm Downpipe System

Colour:

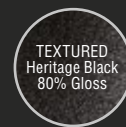

Market sector:

Hospitality

Client:

Robert and Vivien Kyle

"Most rainwater systems do their job as expected, but this is better, as it not only performs extremely well and requires no maintenance, it also looks great once installed. We will definitely use it again on future projects – in fact we are already planning to replace the rest of the rainwater systems on the existing parts of the hotel with Alutec's products."

Robert Kyle,
Owner of Lochside House Hotel



Traditional Gutter Profiles Overview

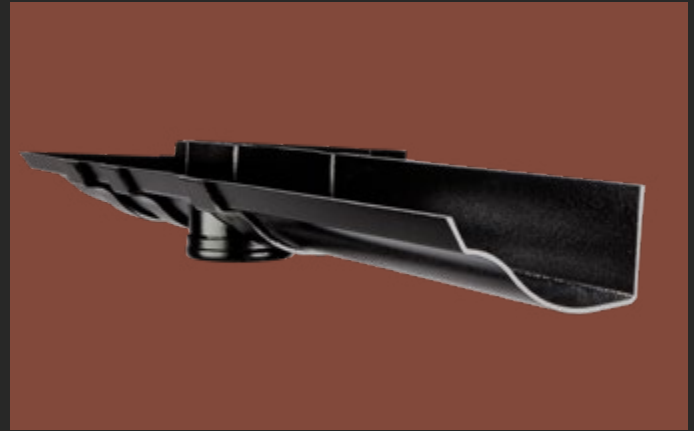

traditional HALF ROUND

- Available in three different sizes
- Flow rate of up to 2.5 l/s and 120m² per downpipe
- Compatible with 63mm, 76mm, 102mm, 72x72mm and 102x76mm downpipes
- Only 2 days lead time for Heritage Black products

traditional VICTORIAN OGEE

- Available in three different sizes
- Flow rate of up to 1.7 l/s and 80m² per downpipe
- Compatible with 63mm, 76mm, 72x72mm and 102x76mm downpipes



traditional MOULDED OGEE

- Available in three different sizes
- Flow rate of up to 5.5 l/s and 263m² per downpipe
- Compatible with 63mm, 76mm, 102mm, 72x72mm, 102x102mm and 102x76mm downpipes
- Only 2 days lead time for Heritage Black 125mm and 150mm product sizes

Restoring the Brew House



Faversham Brewery



SNAPSHOT

Shepherd Neame is Britain's oldest brewer - and while 1698 is the Brewery's official founding date, there is clear evidence that its heritage pre-dates even this period. Located in Kent, beer production has taken place on this site for centuries and whilst Shepherd Neame's dedication to brewing great beer has never wavered, the Victorian brew house, Grade II listed needed restoration.

During this time, the building had lost some of its key features - including the original cast iron gutters, which had been replaced with modern non-characteristic guttering. Re-establishing the heritage characteristics of the building was important to the history of the brewery and that a complete restoration was required.

THE SOLUTION

Alutec's Area Sales Manager at the time, advised on the project and recommended Moulded Ogee gutter system from the Traditional range. Manufactured from marine grade aluminium to original British Standard cast iron dimensions, this traditional style bolted guttering is powder coated to mimic the appearance of cast iron gutters whilst being significantly lighter and easier to install. To complete the cast iron look, this project was also ideal for Alutec's 102mm Tudor Downpipe system.

AT A GLANCE

Products:

- Traditional Moulded Ogee Gutter System
- Tudor 102mm Downpipe System

Colour:

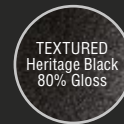

Market sector:

Heritage

Client:

Shepherd Neame

Contractor and Installer:

SG Refurbishment

"The finish is absolutely perfect. We've had no problems with the rainwater systems since installation and they look great. Due to the hard work of everyone involved, Shepherd Neame has been restored to its stunning historical beauty."

Jonathan Arthur,
Senior Surveyor for the Brewery



St Mary's Primary School



Larkhall, South Lanarkshire



SNAPSHOT

St Mary's Primary is located in Larkhall, South Lanarkshire and is classified as a category C listed building by Historic Scotland. Unfortunately, the building suffered fire damage and while no one was hurt during the incident, the building was in need of significant repair. Proposals were put forward that saw the partial demolition, rebuild, refurbishment and extension of the school.

THE SOLUTION

Planning and Building Standards, Community and Enterprise Resources, South Lanarkshire Council gave planning approval and Historic Scotland granted Listed Building Consent for the project, finding both the profile and material of Alutec's products suitable for the application. Installed at the school was the company's 125mm Traditional Moulded Ogee guttering and 102x76mm Traditional downpipes. Made from marine grade aluminium, the guttering has superb performance and sustainability credentials with a functional life expectancy of 50 years. What's more, this impressive life span is virtually maintenance free and the whole system can be fully recycled at the end of its service life.

AT A GLANCE

Products:

- Traditional Moulded Ogee 125mm Gutter System
- Traditional 102x76mm Downpipe System

Colour:

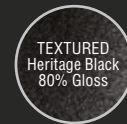

Market sector:

Education
Heritage

Client:

South Lanarkshire Council

"Crucial to the planning process was the use of building materials that would satisfy the listing requirements. Originally built in 1872 it was important that materials contributed to maintaining the traditional external façade whilst also complementing the new build extension. Alutec's aluminium products provided a perfect bridge between new and old, tying the two parts of the building together really well."

Jim McCracken,
Architect at South Lanarkshire Council



The Bedford Lodge Hotel



Newmarket



SNAPSHOT

Having undergone an extensive refurbishment programme, the four-star Bedford Lodge Hotel in Newmarket retains the charm and character of a country house yet offers the very best in modern comfort and luxury. So, when it came to specifying replacement rainwater systems as part of the renovation, choosing a product that would blend sympathetically with the building's traditional exterior was a key.

THE SOLUTION

Manufactured to BS 8530:2010, which replicates precisely original British Standard cast iron dimensions and offers a classic profile, Alutec's Traditional range of gutters and downpipes was the obvious solution. The 125mm Traditional Moulded Ogee gutters, 72x72mm and 102x76mm Traditional downpipe and standard hopper systems in Heritage Black were specified. The Traditional system also ticked the boxes in terms of durability and long-term performance. They are even 65% lighter than equivalent cast iron systems, making it easier and safer to handle and install.

Alutec's Technical Services team was on hand to help specifiers and installers with a wide variety of queries, including correct system choice, roof drainage design, flow rate calculations and installation advice.

AT A GLANCE

Products:

- Traditional Moulded Ogee 125mm Gutter System
- Traditional 102x76mm Downpipe System
- Traditional 72x72mm Downpipe System
- Standard Hopper System

Colour:

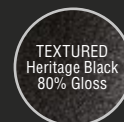

Market sector:

Hospitality

Client:

Bedford Lodge Hotel

Architect:

A Squared Architects

Contractor:

Godfrey and Hicks

Installer:

Dobson and Smith Carpentry

"We're really happy with the refurbishment as a whole and the new rainwater system has certainly contributed to the hotel's smart new look. It's also reassuring to know that the aluminium system has such a long lifespan and that it will need very little maintenance during that time."

Noel Byrne,
Chief Executive of Bedford Lodge Hotel



A traditional farmhouse



Located in the Scottish countryside



SNAPSHOT

As an experienced installer, Shaun Scott understands the importance of finding high-quality solutions, which combine traditional style with modern performance. Located in Inch in the Scottish countryside, Shaun Scott's 200-year-old home is a traditional farmhouse that had been left derelict prior to Shaun purchasing the property. As such, the rustic property, which consists mainly of natural stone and timber features, was in desperate need of an exterior renovation, including refurbishment of its old cast iron guttering, rainwater drainage and eaves.

THE SOLUTION

For Shaun, 2016's UK Plumber of the Year, the challenge was to find products that would fit with the pre-existing farmhouse aesthetic but still provide the performance upgrade that was needed. Shaun first became familiar with Alutec through his membership with the Scottish & Northern Ireland Plumbing Employers' Federation (SNIPEF), of which Alutec is also an associate member. On meeting the company's Area Sales Manager for Scotland at a SNIPEF event, Shaun was introduced to its Traditional range. This innovative aluminium solution provides a low-cost replacement for cast iron downpipes delivering an accurate aesthetic match, long lasting durability with zero maintenance and an easy installation.

For his own project, Shaun opted for a Traditional Half Round gutter system with 76mm Tudor downpipes, all in Heritage Black, perfectly replicating the original cast iron system.

AT A GLANCE

Products:

- Traditional Half Round Gutter System
- Tudor 76mm Downpipe System

Colour:

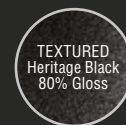

Market sector:

Self-build

Contractor:

Derek Scott Plumbing & Heating

Merchant:

GPH Inverurie

"Working with Alutec has helped me to meet specific project goals in a timely, cost-effective manner. I was already familiar with the benefits of using aluminium rainwater products over alternative materials. Even so, it was fantastic to experience it for myself. From the high flowrate, to its ease-of-installation, it's clear that I have made the right choice. What's more, Alutec's team has been on hand to support me every step of the way, from specification, to installation, which I am very grateful for."

Shaun Scott



Moreteyne Manor house



Bedfordshire



SNAPSHOT

Moreteyne Manor, a traditional Tudor property in Bedfordshire, is home to a popular restaurant and wedding reception venue and is owned and run by husband and wife, Mark and Jacqui Hickman.

The PVC rainwater system which was previously installed had started to discolour due to its age, becoming grey and mottled, which did not look too attractive on the beautiful house and didn't fit with the traditional style. A lot of weddings take place at the manor, with the building as a backdrop to the photographs, but the PVC system was a real eyesore.

THE SOLUTION

Capturing the elegant aesthetics of period architecture, Alutec's Tudor downpipe system and Traditional half round gutter system were installed at Moreteyne Manor, an exclusive Grade II* manor house that dates back to 1562, to replace its old PVC system.

The systems are made from marine grade aluminium and are 65 per cent lighter than cast iron, making it easier to handle on site. Designed as the ultimate rainwater solution for heritage and period style properties, the aluminium Tudor downpipe and traditional gutters features the uniquely textured Heritage Black finish, achieved using polyester powder coated paint. Perfectly emulating the textured finish of cast iron systems, this makes it perfect for conservation areas, renovation projects and classically designed new build properties alike.

"The Alutec aluminium rainwater system has also given us peace of mind, as we know that the products will last for many years and will need virtually no maintenance – which is great news, as it means we can spend the money saved on the restaurant and providing lovely weddings for couples."

Jacqui Hickman, Owner



AT A GLANCE

Products:

- Traditional Half Round 113mm Gutter System
- Tudor 63mm Downpipe System

Colour:

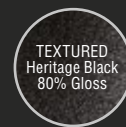

Market sector:

Heritage
Hospitality

Installer:

Aaron Coker

Client:

Mr and Mrs Hickman

Houses in Hermitage Road



Crumpsall, Manchester



SNAPSHOT

A refurbishment of a number of Victorian houses in Manchester. As a part of the renovation, the rainwater system also required urgent change and it was decided by the local council that solution to fit the façade and history of the building will be best option.

THE SOLUTION

The local council considered aluminium rainwater solutions instead of cast iron and PVC. Having a functional life expectancy of more than 50 years, aluminium offers outstanding longevity that does not require regular maintenance. Rather, it simply needs to be occasionally cleaned in order to sustain its immaculate appearance.

This durability is in part due to the thin layer of oxide that develops on the surface of the aluminium to protect it should it sustain any damage, avoiding corrosion. This ensures that aluminium offers a weather resistant solution, with long-term maintenance costs being avoided. Aluminium solutions are also 65% lighter than cast iron, providing a solution that is as easy to transport and install as PVC but with a far greater lifespan.

Furthermore, aluminium is an ecological choice; aside from being an infinitely recyclable material, any environmentally negative restoration and disposal processes are avoided.

AT A GLANCE

Products:

- Traditional Victorian Ogee 125mm Gutter System
- Traditional 76mm Downpipe System
- Fluted Hopper System

Colour:

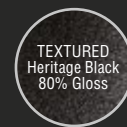

Market sector:

Social Housing

Architect:

Geraldeve, Manchester

Contractor:

Henry Boot

Client:

Manchester City Council

“The chosen marine grade aluminium products from the Traditional ranges ticked all the boxes and provided us with ‘fit and forget’ solution with very minimum maintenance”.



Aligator Gutter Profiles Overview

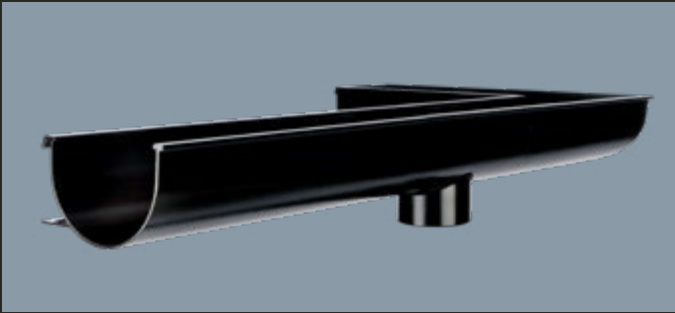

aligator DEEPFLOW

- Internal joints and concealed brackets for a completely smooth finish
- Flow rate of up to 4.4 l/s and 209m² per downpipe
- Compatible with 63mm, 76mm, 102mm, 72x72mm, 102x102mm and 102x76mm downpipes

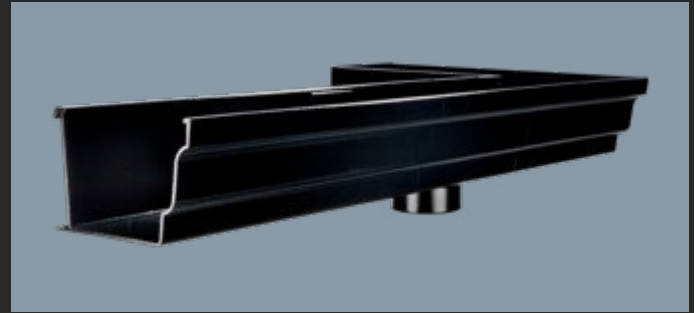

aligator OGEE NO. 46

- Internal joints and concealed brackets for a completely smooth finish
- Flow rate of up to 7.6 l/s and 361m² per downpipe
- Compatible with 63mm, 76mm, 102mm, 72x72mm, 102x102mm and 102x76mm downpipes

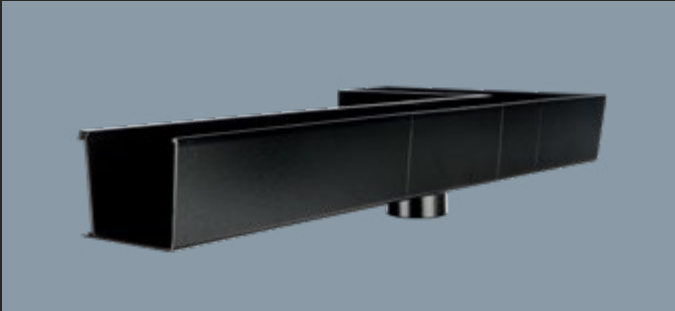

aligator BOXER

- Internal joints and concealed brackets for a completely smooth finish
- Available in three sizes and ideal for small to large properties
- Flow rate of up to 7.4 l/s and 352m² per downpipe
- Compatible with 63mm, 76mm, 102mm, 72x72mm, 102x102mm and 102x76mm downpipes



aligator GIANT

- Commercial size profile with external unions and concealed supports
- Flow rate of up to 10.7 l/s and 512m² per downpipe
- Compatible with 76mm, 102mm, 72x72mm, 102x102mm and 102x76mm downpipes



aligator CLASSIC

- Domestic size ogee style profile with external unions and brackets
- Flow rate of up to 4.1 l/s and 196m² per downpipe
- Compatible with 63mm, 76mm and 72x72mm downpipes
- Only 2 days lead time for Heritage Black products

Reymerston Hall



Norfolk



SNAPSHOT

Located in Norfolk, Reymerston Hall is a six-bedroom, Grade II listed, Georgian property with over 11.5 acres of land. Famously, the property was home to Sir Ken Wallis where he lived and flew for over 60 years. In addition to the house there is a two-storey brick and tile barn, as well as a hangar and workshop where Sir Ken kept and worked on his collection of autogyros.

Following four years of inhabitation, Reymerston Hall was put up for auction by Sir Ken Wallis' family and sold to Liz & Keith Holbrook who are now restoring the property to become an idyllic wedding venue.

THE SOLUTION

Alutec's aluminium Aligator Ogee 46 gutter system and Traditional downpipes were specified for the renovation of Reymerston Hall, previously home to James Bond stunt man and Wing Commander, Sir Ken Wallis. Selected due to its specialism in conservation and heritage properties, Alutec manufactured bespoke gutter offsets to accommodate the difficult building dimensions.

Due to the age and condition of the property, Reymerston Hall needed a complete roof replacement. Specified by both contractor, K M Holbrook and the listed conservation officer Andrew Gayton, Alutec provided the ideal guttering solution that integrated the old and new aspects of the building.

AT A GLANCE

Products:

- Aligator Ogee No.46 Gutter System
- Traditional 102x102mm Downpipe System

Colour:



Market sector:

Heritage
Hospitality

Contractor:

K.M.Holbrook

Sub-Contractor:

RH Roofing Ltd

Merchant:

Ridgeons Sawbridgeworth

"Alutec's products were simple to install and I appreciated the technical support that we received. This included a full-site survey and on-site assistance."

Ross Hardingham,
Director at RH Roofing Ltd



Private residence



Killin, Stirling



SNAPSHOT

The now four-bedroom residential property in the village of Killin, was extensively redeveloped and extended from the original one-bedroom home, much of which was demolished to create the new property. The design included aluminium panel for the fascia and soffits to provide a high quality, long lasting finish for the exterior of the property. The specification also included aluminium rainwater systems due to the material's longer lifespan when compared with PVCu systems.

THE SOLUTION

Demonstrating its versatility and ease of installation, Alutec's Evoke aluminium composite fascia and soffit system has been supplied where it was cut and formed on-site from standard sheets to meet the requirements of the project. Aligator Deepflow gutter system was also chosen for its strength, durability and simple installation process. Both the Evoke and Aligator systems were supplied in RAL 7016 Anthracite Grey to match other elements of the property such as the aluminium framed windows.

AT A GLANCE

Products:

- Evoke Fascia and Soffit System
- Aligator Deepflow Gutter System
- Flushfit Downpipe System

Colour:



Market sector:

Private Housing

Contractor:

Ian Brydie Construction

"Seamless aluminium gutters had been specified and on previous builds we have worked with a specialist subcontractor to fabricate it. However, we realised that with the Alutec Snap-fit solution we could achieve a seamless look but with a system that we could install ourselves. We presented this option to the client and they were keen for it to be used, especially given its strength and longevity."

Ian Brydie,
the owner of Ian Brydie Construction



St Michael's Primary School



Southfields, London



SNAPSHOT

Thanks to the expert support of its technical team and the long-term durability of its products, Alutec's rainwater and eaves systems have been installed as part of this major refurbishment project.

THE SOLUTION

The project has expanded the school's capacity with the construction of a new build extension, as well as an extensive internal refurbishment of the existing buildings. The rainwater specification initially called for aluminium gutters attached to timber fascia. However, after consulting with Alutec's technical team, Jason Tait, architect at Wandsworth Council, decided to opt for products from Alutec's Evoke fascia and soffit range instead, to maximise the longevity of the system as a whole. Manufactured from highly durable composite aluminium, the Evoke range is a low maintenance and long-lasting alternative to timber, sheet aluminium or plastic eaves systems.

Jason specified the Evoke system in the white RAL 9010 colour, combining it with Alutec's Aligator Classic gutter and Traditional 63mm downpipe in black, resulting in an extremely durable and low maintenance system overall.

AT A GLANCE

Products:

- Aligator Classic Gutter System
- Traditional 63mm Downpipe System
- Evoke Fascia and Soffit System

Colour:

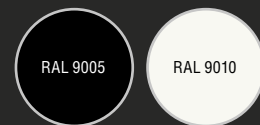

Market sector:

Education

Architect:

Wandsworth Council

Contractor:

Lengard

Merchant:

Travis Perkins

"The technical advice from Alutec was really valuable and definitely helped ensure the design and installation process went smoothly. For example, the team was able to advise on drainage from the building's flat roof, via a hopper to the adjoining pitched roof, which helped us solve that particular design challenge. Overall, I'm really happy with the products and service from Alutec and would certainly specify them again in the future."

Jason Tait,
Architect at Wandsworth Council



Warren Wood Manor



Hertfordshire



SNAPSHOT

Alutec supplied a range of its aluminium rainwater products to this beautiful mansion as part of a sensitive refurbishment project to improve performance while maintaining the building's historic aesthetic. The new build mansion is complete with a 24-car private garage, cart and hay lodge and a 45-horse stable, which plays host to a popular local riding club. The project, which began in September 2013 saw major work carried out to update some of the manor's older features.

THE SOLUTION

As the developers were working on a building with such a focus on quality it was important, they chose a rainwater system that was of similar high standard. Alutec's Aligator range provides this and as such was the perfect choice - durable and strong the system has internal joints and concealed brackets, offering a sleek and unobtrusive solution.

The opulent £19 million mansion has been fitted with products from Alutec's Aligator range. The main house has been equipped with an Aligator Ogee No.46 gutter system and 102mm Traditional circular downpipe, whilst the carriage house has been fitted with the Aligator Classic gutter system and 63mm Aligator Classic circular downpipe.

AT A GLANCE

Products:

- Aligator Ogee No. 46 Gutter System
- Traditional 102mm Downpipe System
- Aligator Classic Gutter System
- Classic Downpipe System

Colour:

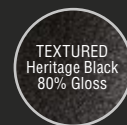

Market sector:

Private Housing

Client:

Homeowner

Contractor:

Tony Penfold

"This mansion has been built to stand for many years to come so it's important we can feel assured that during this period it has a reliable, effective and efficient rainwater system. With Alutec products installed that's now guaranteed!"

Tony Penfold,
Lead Developer



National Golf Resort and Spa



Uckfield, East Sussex



SNAPSHOT

A £14.4m development, the East Sussex National Golf Resort consists of a 110-beds hotel, spa, conference centre and two championship golf courses.

THE SOLUTION

To match with the requirements of the client, a profile from the Aligator range was specified. The Aligator Boxer is with internal joints and concealed brackets, offering a sleek and unobtrusive solution for modern building design. Durable and strong - Manufactured from marine grade aluminium, making the Aligator range more corrosion resistant than other grade aluminium systems, steel or cast iron products.

Aligator Boxer gutter system is with patented Aligator Snap-Fit joint system, proven to reduce installation times by up to 40% compared to traditional bolted systems.

The Aligator range offers functional life expectancy of 50 years or more with minimal maintenance, only periodic aesthetic cleaning required.

AT A GLANCE

Products:

- Aligator Boxer Gutter System
- Traditional 102x76mm Downpipe System

Colour:



Market sector:

Hospitality

Architect:

Morgan Carn Architects, Brighton

Contractor:

Quadric Contractors

Developer:

Quadric Chartered Building Company

A unique renovation and self-build project



Kent



SNAPSHOT

Taking advantage of the contemporary lines of Alutec's composite aluminium Evoke fascia and soffit system and Aligator Boxer guttering, a unique renovation and self-build project in Kent has blended modern style and technologies with traditional architecture.

The first phase of the project involved the complete renovation of an old Methodist Chapel located on the site in Goudhurst, Kent, while the second has seen an ambitious new build take shape called Chapel View. Nick Leggett, a chartered surveyor and Partner of NDL Consulting, and his business and life partner Sonja Johnson took on the project with the view of creating two properties that complimented each other, whilst both having their own distinct style.

THE SOLUTION

Started in September 2013, Chapel View is a 2,000 square foot dwelling and was built using an insulated concrete formwork (ICF) system. Sitting partly below ground with 600 tonnes of earth having been removed from the site, the property hunkers down into its surroundings. The three-storey contemporary home enjoys stunning views and impressive eco-credentials, with no heating required and sustainable materials used throughout.

After seeing Alutec's Evoke fascia and soffit and Aligator Boxer ranges at a recent trade show the owner knew it was the perfect fit for this project as its square box sections provided the contemporary detail he wanted.

AT A GLANCE

Products:

- Aligator Boxer Gutter System
- Traditional 72x72mm Downpipe System
- Evoke Fascia and Soffit System

Colour:

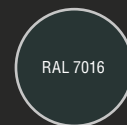

Market sector:

Private Housing
Self-build

Client:

Nick Leggett and Sonja Johnson

"Central to the design of our new home was our desire to build responsibly and efficiently. The sustainability of Alutec's products and the thermal efficiency of our exterior envelope using the ICF system, were key factors in helping us to build in this way and I would highly recommend them to other self-builders."

Nick Leggett,
Chartered Surveyor



Rainwater Solutions - Downpipe Systems

Alutec's marine grade aluminium downpipe systems are available in a wide variety of aesthetics to suit all styles of property, offering a functional life expectancy of 50 years or more with minimal maintenance, only periodic aesthetic cleaning required. The colour range is 19 standard colours with architectural grade polyester powder coat (PPC) paint finish, including Heritage Black which has a textured surface to accurately replicate the appearance of traditional cast iron.



EVOLVE DOWNPIPES

- Available in 63mm size
- For use with the Evolve Half Round gutter system
- Only 2 days lead time in Heritage Black and Anthracite Grey (RAL 7016) colours



FLUSHFIT DOWNPIPES

- Available in 63mm, 76mm, 102mm, 72x72mm, 102x76mm and 102x102mm sizes
- Sleek downpipe system with internal joints for modern building designs
- Only 2 days lead time in Heritage Black and Anthracite Grey (RAL 7016) for 76mm and 72x72 products



TUDOR DOWNPIPES

- Available in 63mm, 76mm and 102mm sizes
- The ultimate low-cost replacement for cast iron downpipes
- Only 2 days lead time in Heritage Black colour for 63mm and 76mm products



VANDAL RESISTANT DOWNPIPES

- Available in 72x72mm, 102x76mm and 102x102mm sizes
- Back to wall fixing with no projecting profiles make it non-climbable and vandal resistant
- Ideal for public or higher security areas



TRADITIONAL DOWNPIPES

- Available in 72x72mm, 102x102mm and 102x76mm sizes
- Cast socketed downpipe system for modern and traditional buildings
- A perfect replacement for cast iron downpipes

Rainwater Solutions - Hopper Heads

The widest range of marine grade aluminium hoppers on the market, offering a functional life expectancy of 50 years or more with minimal maintenance, only periodic aesthetic cleaning is required. The colour range is 19 standard colours with architectural grade polyester powder coat (PPC) paint finish, including Heritage Black which has a textured surface to accurately replicate the appearance of traditional cast iron. Bespoke hoppers are available on request.



STANDARD HOPPERS

- Available in size 250x180x180mm
- Compatible with downpipe sizes 63mm, 76mm, 102mm, 72x72mm, 102x102mm and 102x76mm
- Ideal for small properties



CONTEMPORARY HOPPERS

- Available in three different options – standard, large and extended
- Compatible with downpipe sizes 63mm, 76mm, 102mm, 72x72mm, 102x102mm and 102x76mm
- Sleek and modern solution for rainwater disposal with highest flow rates on the market



ORNAMENTAL HOPPERS

- Available in size 410x190x185mm
- Compatible with downpipe sizes 63mm, 76mm, 102mm, 72x72mm, 102x102mm and 102x76mm
- Ideal for replacement of old cast iron system or reflect traditional styling on new building



FLUTED HOPPERS

- Available in size 285x21x225mm
- Compatible with downpipe sizes 63mm, 76mm and 72x72mm
- Complete the cast iron look on your property

The Dumfries House Estate



Scotland



SNAPSHOT

The timeless aesthetics of Alutec's aluminium rainwater systems have led to them being specified as part of a leading sustainable homes project by the Prince's Foundation for Building Community.

As an educational charity focused on promoting timeless and ecological construction methods, the Prince's Foundation has designed and built three exemplar properties, with the intention of demonstrating that new build homes can be sustainable, beautiful and imaginative. The properties were initially created for the Ideal Home Show in 2014, where they were exhibited to the public before being permanently relocated to the Dumfries House Estate, in Scotland.

THE SOLUTION

The homes have been built according to the Prince's Foundation's Natural House model, which is designed to achieve high standards of sustainability through the careful selection of materials, while simultaneously maintaining a focus on traditional design. Alutec's Traditional and Tudor ranges were specified as they delivered the required combination of environmental performance and classic visual appeal in RAL 3004, special order paint designed to match the Dumfries Estate's official colour scheme. They offer the classic look of cast iron rainwater systems, but with the modern performance characteristics expected from 21st century homes. Critically, the aluminium ranges deliver performance benefits that could never be achieved using cast iron, such as easy installation and minimum maintenance, as well as excellent longevity, durability and sustainability.

AT A GLANCE

Products:

- Traditional Half Round 113mm Gutter System
- Tudor 63mm Downpipe System

Colour:



Market sector:

Private Housing

Architect:

David Richards Associates

Client:

Prince's Foundation for Building Community

"The Prince's Houses aim to showcase how modern eco-homes can still take inspiration from tradition whilst providing all the benefits and comforts of modern living."

The Prince's Foundation



Community facility



Telford, Shropshire



SNAPSHOT

An important new community facility in Telford, Shropshire, has achieved the highly prized PassivHaus standard for low energy consumption, while the overall sustainability of the building's design has included the use of a bespoke aluminium soffit and fascia system with an integral roof gutter detail, provided by Alutec.

THE SOLUTION

The New Town Park Visitor Centre, which stands near the ice rink in the Southwater area of Telford, was designed by Telford & Wrekin Borough Council's own Architects Department, while the Wygar Construction Company Limited was the main contractor. Roweaver, a national specialist for the installation of eaves systems, meanwhile, worked in coordination with the roofing and cladding sub-contractors to ensure the £23K package of Alutec products were fitted in sequence with the rest of the work on waterproofing and finishing the building envelope.

As planned, the Southwater development include an 11 screen cinema, an 82 bedroom hotel, a refurbished ice rink and a number of new bars and restaurants; together with new homes and retail units.

AT A GLANCE

Products:

- Flushfit 72x72mm Downpipe System
- Standard Hopper System
- Alligator Boxer Gutter System
- Bespoke Fascia and Soffit Systems
- Bespoke Coping System

Colour:

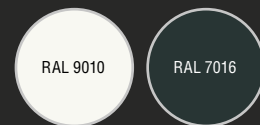

Market sector:

Hospitality

Client:

Telford & Wrekin Borough Council

Contractor:

Wygar Construction Company Limited

Installer:

Roweaver Developments Ltd.

"Alutec was selected for this important project due to the fact the manufacturer was able to offer proactive design proposals, including some bespoke solutions - throughout the pre-contract phase. This is a very visible building providing an important facility as part of a major development intended to create a vibrant and sustainable heart for Telford's town centre."

Spokesperson for the project team





FM Mosque

 Peterborough

SNAPSHOT

Square cream downpipes and hoppers are ensuring a durable and low maintenance rainwater solution whilst complementing the intricate stonework at the FM Mosque, set in the town of Peterborough.

THE SOLUTION

With a brief to provide fittings that matched the render and blended unobtrusively into the façade of the mosque, the non-standard BS cream colour of the 102 x 76mm Aluminium downpipes and hoppers was specially sourced by Alutec.

Manufactured from marine grade aluminium, Alutec offers a resilient rainwater solution. Aluminium is more durable than zinc and lighter than cast iron. It is also infinitely recyclable, ensuring an environmentally friendly solution and has the added benefit of not needing to be repainted.

AT A GLANCE

Products:

- Traditional 102x76mm Downpipe System
- Standard Hopper System

Colour:



Market sector:

Places of Worship

Client:

The Mosque authorities

Merchant:

Andrews Building Supplies

“We have a long-standing relationship with Alutec and are always impressed with the level of expertise and complete service they provide. The fittings look fantastic and everyone involved with the project is delighted with the outcome.”

Bernie Tyson,
Managing Director of Andrews Building Supplies



Woodside Square development



North London



SNAPSHOT

Woodside Square is a redevelopment of St. Luke's Hospital, located in the Muswell Hill area of North London since 1930. The new six-acre development comprises of 159 one, two, three- and four-bedroom homes created specifically for over 55s, with options intended to allow downsizing from family homes while staying within the Muswell Hill area.

THE SOLUTION

Architect Pollard Thomas Edwards' design captured the contemporary arts and crafts style typical of the post-Edwardian area in this gentrified location by using high quality materials and incorporating beautiful design details. Aluminium was chosen as the ideal material for juxtaposing careful restoration against modern styling. Sustainability was a key part of the concept not only in terms of ensuring energy efficiency but also in the building materials chosen. The low environmental impact and infinite recyclability of aluminium further justified its use for the scheme.

The site management team at Hill Partnerships was keen to retain its trusted trades. Alutec produced material schedules for procurement of fascia, soffit, and rainwater goods for the contemporary flats. On-site installer training was then trailed on the first block. The Admin block used Moulded Ogee gutters to BS8530 as an authentic replacement for the existing cast iron, modified for rear outlet discharge into in-situ pipework. The Roseneath and Norton Leas blocks were one of the first orders for Alutec's new Tudor 102mm pipe range. The design and production of bespoke gutter and pipe fittings enabled the unobtrusive installation of the systems to meet the design brief, including outlets for the balconies.

"With modern new builds being constructed alongside the renovation of heritage buildings, establishing a degree of continuity across the site was important. Alutec was able to supply products that would suit each application, providing a single source of supply with efficiency and expertise."

Chris O'Dowd, Project Manager at Hill Partnerships



AT A GLANCE

Products:

- Alligator Boxer Gutter System
- Traditional Moulded Ogee Gutter System
- Traditional Victorian Ogee Gutter System
- Tudor 102mm Downpipe System
- Flushfit Downpipe System
- Bespoke Products
- Evoke Fascia and Soffit Systems
- Balcony and Roof Outlet Systems

Colour:

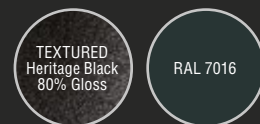

Market sector:

Social Housing

Architect:

Pollard Thomas Edwards

Contractor:

Hill Partnerships

Merchant:

Travis Perkins

Eaves Solutions - Fascia and Soffit

Our Evoke range of aluminium fascia and soffit delivers stunning visual impact and value for money and perfectly complements the long-life expectancy and low maintenance of Alutec aluminium gutter and downpipe systems.

Our standard fascia and soffit systems are manufactured from 4mm thick aluminium composite material. These products are suitable for use up to a maximum height of 18m. For installations carried out above 18 metres in height, and for non-standard colour requirements, our solid sheet aluminium products are available.

- Installs like PVC, no specialist trades required
- Various profiles and sizes available
- Can be fixed directly to roof truss ends
- 12 different PVDF paint colour options that will naturally resist the build-up of dust, grime and algae, keeping maintenance costs to a minimum



FASCIA TYPE A

- 30mm x 45° return fascia system, 3m panels
- 6 standard fascia depths from 120 - 450mm
- Non standard fascia depths and designs available to order
- 12 standard colour options
- Ideal for use on all building types



VENTED SOFFIT

- Slotted to give 25mm continuous ventilation area, 3m panels
- 6 standard soffit widths from 100 - 740mm
- Non standard soffit widths available to order
- 12 standard colour options
- Ideal for use on all building types



FASCIA TYPE B

- 30mm x 90° return fascia system, 3m panels
- 6 standard fascia depths from 150 - 460mm
- Non standard fascia depths and designs available to order
- 12 standard colour options
- Ideal for use on all building types



UNVENTED SOFFIT

- Available in 3m panels
- 6 standard soffit widths from 100 - 740mm
- Non standard soffit widths available to order
- 12 standard colour options
- Ideal for use on all building types



FASCIA TYPE C

- 30mm x 25mm return fascia system, 3m panels
- 5 standard fascia depths from 150 - 435mm
- Non-standard fascia depths and designs available to order
- 12 standard colour options
- Ideal for use on all building types

A stunning new build property



Stapeley, Cheshire



SNAPSHOT

Located within the Cheshire countryside, Broadoaks is a newly built, two-storey contemporary building. N C Architecture designed the property with a holistic approach adding emphasis on sustainability – a key requirement of the client – by incorporating solar panels and a ground source heat pump to the property to improve energy efficiency. Due to the homeowner's requirements and the property's modern aesthetic, the architect required a sustainable aluminium guttering system that would complement the design of the build.

THE SOLUTION

Evoke fascia type A was used on the sloping eaves and type B on the bargeboards. Bespoke box end corners were designed to ensure the transition from eaves to bargeboard was unobtrusive yet easy to install. Evolve Ogee rainwater gutters and Flushfit downpipes were chosen to compliment the contemporary nature of the build, all in RAL7016 Anthracite grey colour.

Only Alutec's fixings and consumables were used such as cleaners and sealants, recommended to ensure the level of durability expected of product manufactured from polyester powder coated marine grade aluminium. At the end of the building's life, all materials can be fully recycled an infinite number of times.

AT A GLANCE

Products:

- Evolve Ogee Gutter System
- Flushfit Downpipe System
- Evoke Fascia and Soffit Systems
- Bespoke Products

Colour:

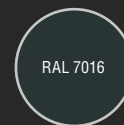

Market sector:

Private Housing

Architect:

N C Architecture

Main Contractor:

RHB Construction

Merchant:

Buildbase

"We felt a total aluminium eaves approach could provide the level of durability and styling options to meet the homeowner's design brief. The property required a sleek, contemporary look with minimal maintenance."

Tony Kaba,
Senior Architect at N C Architecture



Sheffield City Council re-roofing project



Sheffield



SNAPSHOT

Alutec has designed and supplied bespoke fascia and soffit solution and rainwater systems for a major refurbishment project for Sheffield City Council, which will go on to transform 26,000 homes over the next five years – making it the largest roofing project in UK history.

THE SOLUTION

Following a stringent tendering process, Alutec’s aluminium rainwater products were specified because of the council’s commitment to provide housing and services that go beyond the industry standard. In particular, the impressive durability, lifecycle costs, sustainability credentials and almost zero maintenance requirements of Alutec’s products meant that they were a perfect fit for such a quality conscious project. Importantly, they were also approved by members of the Sheffield Tenants and Residents Association as Sheffield City Council modelled an open communication and inclusion policy throughout the project.

Phase one of the project involved remodelling a proportion of the flat roofed properties, including installation of external insulation to reduce thermal bridging and fuel poverty behind the fascias, as well as changing the roofs from being centrally to externally drained. Alutec’s technical team worked closely with the council and the contractor to produce a unique and innovative design for the eaves detailing that encapsulated the insulation with its high-quality Evoke fascia and soffit system.

AT A GLANCE

Products:

- Evoke Fascia and Soffit Systems
- Evolve Deepflow Gutter System
- Flushfit 76mm Downpipe System
- Balcony Outlet System
- Bespoke Products

Colour:

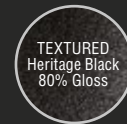

Market sector:

Social Housing

Client:

Sheffield City Council

Contractor:

Kier Group, Keepmoat, SBS and BAAS

Merchant:

SIG Group

“We’re delivering a massive £300m investment programme for our council homes over five years, to make them better for tenants. We’re pleased to be working with Alutec and are looking forward to seeing the end results.”

Janet Sharpe,
Director of Housing and Neighbourhoods Service at Sheffield City Council



South Holderness Technology College



Hull, East Yorkshire



SNAPSHOT

South Holderness Technology College in East Yorkshire has safely managed to overcome its asbestos problem thanks to Alutec's expert knowledge and unique aluminium Evoke fascia and soffit system. Built in the 1950s it was constructed with a flat roof using asbestos cement roof decking. The roofing system used continuous asbestos cement sheets to form both the internal ceiling finish and the external soffits, so removal of these boards was not an option.

THE SOLUTION

Whilst they are perfectly safe if undamaged and intact, the soffits had been painted and cross contamination had occurred between the paint and asbestos, meaning any flaking paint was a risk to the students and staff. The building surveyors within the Infrastructure and Facilities team at East Riding of Yorkshire Council therefore took steps to eliminate the potential risk of future exposure to the site users by working closely with Alutec to provide a solution.

Alutec's technical department came up with a bespoke solution to manage the asbestos risk by using its Evoke fascia and soffit system. One of the main challenges was that in some areas the asbestos soffits were extremely wide so designing a system that could span that distance without the need to fix into the asbestos was difficult. Alutec partnered with the installer on site to come up with a bespoke soffit support design that fixed into the external cladding as opposed to the asbestos itself.

AT A GLANCE

Products:

- Evoke Fascia and Soffit System
- Flushfit 76mm Downpipe System
- Standard Hopper System
- Bespoke Products

Colour:



Market sector:

Education

Client:

East Riding of Yorkshire Council – Building Facilities

Contractor:

Hall Construction

Installer:

Amazon Rainwater Systems

"We have been thoroughly impressed with Alutec's flexibility, technical capabilities and products. The college is now much better prepared for modern educational needs and the staff and pupils are well protected from the asbestos risk. We would use this solution again if the need arose and I look forward to working with Alutec again on future projects."

Paul Bentley, Principal Building Surveyor at the Council



The Rookery housing project



Stockton-on-Tees



SNAPSHOT

A collaboration between independent North East builder, T C Developments and leading aluminium rainwater and eaves systems manufacturer, Alutec, has resulted in The Rookery housing project being nominated for a Local Authority Building Control (LABC) award.

THE SOLUTION

The Rookery, a complex of three executive apartments in Stockton-on-Tees, incorporates Alutec's Evoke fascia and soffit system and Flushfit square downpipes, all in RAL 7015 slate grey colour as a fundamental aspect of its roofing design. Working as both the product manufacturer and technical adviser for the system design, Alutec helped the developers showcase good project teamwork, a key part of the awards' judging criteria.

The developer was looking to achieve a subtle, modern design with sleek lines and had initially specified an external rainwater system. However, when reviewing the plans with Alutec it was decided this approach would not achieve the desired aesthetic. After providing expert technical advice it was decided an internal rainwater system incorporating the 72mm x 72mm Flushfit downpipe best suited the overarching architectural ambition.

AT A GLANCE

Products:

- Evoke Fascia Type B System
- Evoke Unvented Soffit System
- Flushfit 72x72mm Downpipe System

Colour:

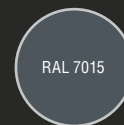

Market sector:

Private Housing

Client:

T C Developments

"We made a great decision working with Alutec when developing The Rookery. As an independent developer it is essential the products I use are both easy to install and durable. This is exactly what I found the Evoke range to be; it was one of the easiest fascia and soffit systems I've ever installed."

Tony Cuthbert,
Director at T C Developments



Vanwall – A modern private home



Guildford



SNAPSHOT

When a private home in Guildford required a total eaves system in line with the architect's vision, Alutec was specified to create a bespoke solution. Working closely with RC Grant & Sons Ltd and the architect Studio Bam!, the eaves system fits perfectly onto the building framework while being totally weathertight. Vanwall is a private home designed by Studio BAM! architects. One of the defining architectural features of this new build home is the overhanging roof – protruding significantly, it is a unique roofline focal point demanding a sleek, bespoke solution.

THE SOLUTION

Due to the nature of this overhang, maintenance would be extremely difficult for the homeowner to carry out. Therefore, a fit-and-forget eaves system was required that would not only fit the unique roofline element but would also mean zero maintenance.

The desired detail was a complex coping and fascia system, with flat soffit boards and cill trim. The design brief was an all-aluminium eaves system, with no protruding joint pieces or visible fixings. Of course, the system also had to be entirely weathertight.

Upon receiving the architect's requirements, the Alutec technical team created CAD section drawings with 3D images using their own in-house software, to illustrate the two design solutions offered and their differing applications.

AT A GLANCE

Products:

- Evoke Fascia Type A System
- Bespoke Cill Trims
- Evoke Coping System

Colour:

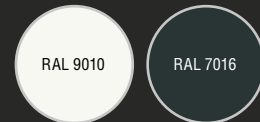

Market sector:

Private Housing

Architect:

Studio BAM! Architects

Client:

RCG External Building Solutions

“One of my colleagues had worked with Alutec prior to this project, so I was confident in the recommendation from them and Adam Farrell. We were impressed by the early commitment to the project, with members of the technical team attending a site visit to discuss the detailing process. The project went well, and we're very happy with the finished product.”

Tom Borowiecki, Director at Studio BAM! Architects



Tynings - A seafront property



Woolacombe, North Devon



SNAPSHOT

Originally built in the late 1960s overlooking Woolacombe Bay and the Bristol Channel, the residential property's coastal location is subject to increased wind exposure. After discovering Alutec's aluminium rainwater solutions online, the project's contractor approached Alutec as the system offered both the necessary rigidity and site workability needed for the window trim.

THE SOLUTION

Alutec was specified to deliver a range of products, including a bespoke window trim solution, to update the dated façade of Tynings, a seafront property in North Devon. With its technical team working closely with the project's contractor, Alutec provided the bespoke design to facilitate a simple installation process.

The full refurbishment consisted of an internal and external upgrade with the correct blend of modern and natural materials needed to sharpen up the property's façade to meet aesthetic and performance requirements.

In addition, matching Evoke fascia, soffits and coping were also installed on the façade, with further coping used around Tynings' stone chimney. It was also specified square rainwater downpipes and balcony outlets - ensuring a consistent and complementary aesthetic across the entire property. Due to the balcony outlets having a circular spigot as standard, Alutec adapted each unit to have a square spigot. This enabled the connection between the outlet and downpipe to be a simple process of pushing them together, neatly concealed within the balcony's soffit.

AT A GLANCE

Products:

- Evoke Fascia and Soffit System
- Evoke Coping System
- Balcony Outlets System
- Bespoke Window Trims

Colour:



Market sector:

Private Housing

Architect:

InkSpace

Contractor:

St Michaels Properties

Merchant:

RGB Supplies

"The technical support from Alutec was invaluable. I explained to Alutec what I wanted to achieve, and we worked together to design a solution that would be possible to implement."

Nick Pullen, St Michaels Properties



Eaves Solutions - Coping

Marine grade aluminium coping system with a decorative polyester powder coated finish. Ideal for use where exceptional durability and aesthetics are key.

- Easy to position and fix without damage to panels
- Thickness of panels is 2mm (for up to 400mm wall width) or 3mm (for over 400mm wall width)
- Weathertight butyl adhesive seal - will maintain a 100% weathertight seal throughout its lifespan and outlast EPDM compression seals normally used in coping systems
- Fire rating A2-s1, d0 (Unlimited use)
- Choice of 19 architectural grade PPC range of standard RAL colours
- Bespoke design service and technical support available

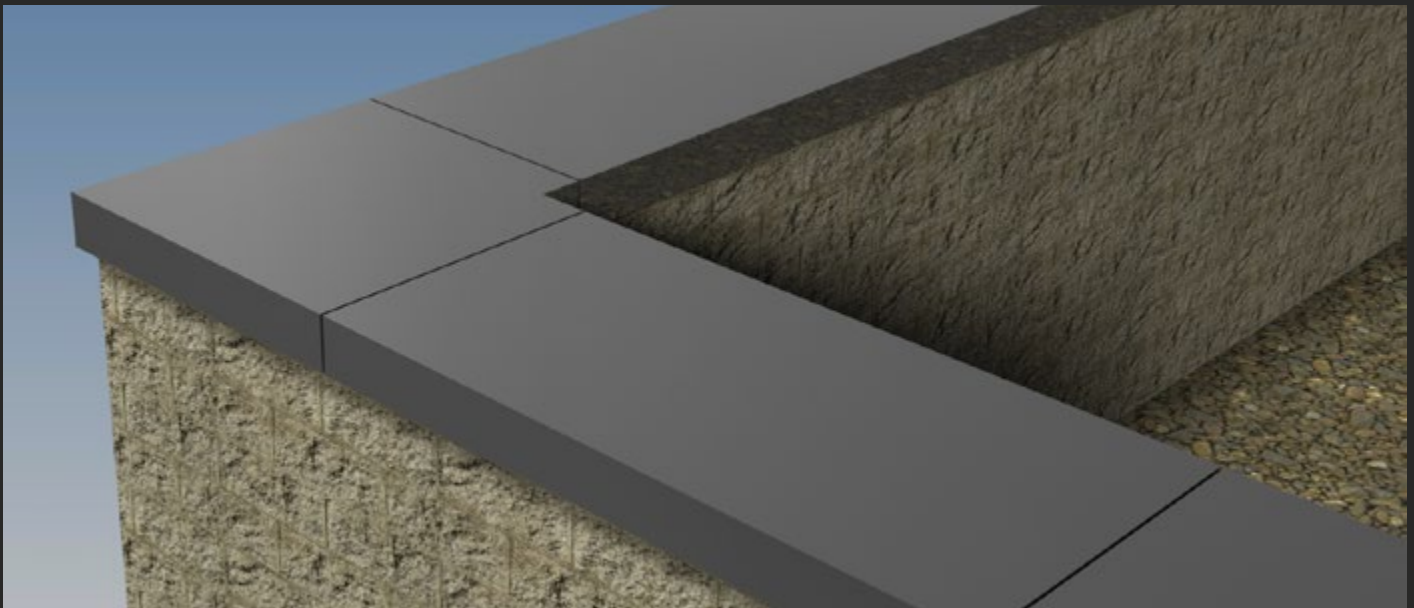

COPING SYSTEMS

A great choice of sizes:

- For 100-160mm wall width - Actual coping width 202mm, 3m panels
- For 161-220mm wall width - Actual coping width 262mm, 3m panels
- For 221-280mm wall width - Actual coping width 322mm, 3m panels
- For 281-340mm wall width - Actual coping width 382mm, 3m panels
- For 341-400mm wall width - Actual coping width 442mm, 3m panels
- For 401-460mm wall width - Actual coping width 502mm, 3m panels
- For 461-520mm wall width - Actual coping width 562mm, 3m panels
- For 521-580mm wall width - Actual coping width 622mm, 3m panels
- For 581-640mm wall width - Actual coping width 682mm, 3m panels
- For 641-700mm wall width - Actual coping width 742mm, 3m panels
- For 701-760mm wall width - Actual coping width 802mm, 3m panels
- For 761-820mm wall width - Actual coping width 862mm, 3m panels
- For 821-880mm wall width - Actual coping width 922mm, 3m panels

Magnolia House - support centre



Birmingham Children's Hospital, Birmingham



SNAPSHOT

Magnolia House, a new purpose-built £1million support centre at Birmingham Children's Hospital is a first of its kind development; the non-clinical, single storey building is in a central part of the hospital's site. It's been designed to provide a safe-haven for parents and families at their time of need, as well as providing a neutral space to facilitate difficult conversations. The centre is home to three dedicated pastel-coloured private counselling rooms, a calming lounge area, a siblings play area and a private peaceful garden where families can sit and reflect.

THE SOLUTION

Products from Alutec's Evoke fascia, soffit and coping ranges were used throughout the project. Combining exceptional durability and aesthetic appearance, the ranges perfectly complimented the ethos of the project. Also installed at the project was Alutec's Aligator Boxer boltless guttering and Flushfit downpipes. As with all of the company's aluminium products, the system requires no specialist tools or contractors to fit or adapt on site and are extremely lightweight and easy to install. In addition, aluminium is one of the world's most sustainable materials and is 100 per cent recyclable at the end of its extended life span.

AT A GLANCE

Products:

- Evoke Fascia and Soffit System
- Evoke Coping System
- Aligator Boxer Gutter System
- Flushfit Downpipe System

Colour:

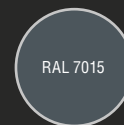

Market sector:

Healthcare

Client:

Birmingham Women's and Children's NHS Foundation Trust

Architect:

Pinnegar Hayward Design

Contractor:

Marshdale

Merchant:

SIG Erdington

"It can be challenging to integrate curved eaves into a building design, and we had to ensure we specified the right products. I've had experience with Alutec previously and was confident in using their eaves systems. The fact the company can produce bespoke pieces is a big advantage, as designs can sometimes be constrained by off the shelf products."

Dan Brown,
Project Led at Pinnegar Hayward Design



An impressive new combined services centre



Llandrindod Wells, Wales



SNAPSHOT

Housing Mid and West Wales Fire and Rescue Service, Dyfed Powys Police and Her Majesty's Court and Tribunal Service, the new building features a sedum roof and larch timber clad walls. With multiple performance attributes demanded by the living roof, Lawray Architects stated that the chosen soffit, fascia and coping system must be lightweight and durable, as well as complementing the building's modern aesthetic appearance. Roofing contractors, M A Hartley were contracted to install the products and were quick to recommend Alutec. After examining some sample products, Lawray Architects were happy to confirm the specification.

THE SOLUTION

Working to the client's specific brief, Alutec designed a system comprising individually designed soffit, fascia and coping, with bespoke Flushfit 102mm Ø downpipes – all in a custom shade of soft grey. Manufactured to meet the highest standards of durability and reliability, Alutec's soffit, fascia and coping systems offer a lightweight alternative to PVC or sheet aluminium solutions. Comprising a recycled polyethylene core, with a composite aluminium outer layer and high performance PVDF paint, the system is extremely durable, with a functional life expectancy of 50 years or more.

AT A GLANCE

Products:

- Evoke Fascia and Soffit System
- Bespoke Evoke Coping System
- Bespoke Flushfit 102mm Downpipe System

Colour:

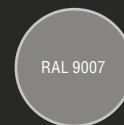

Market sector:

Municipal

Architect:

Lawray Architects

Contractor:

John Weaver (Contractors) Ltd

Installer:

M A Hartley Roofing Contractors

Merchant:

Wolseley Cardiff

"We are really happy with the system and have been quite impressed by both the speed of installation and the look that it adds to the building. It gives a really sleek finishing touch to the front elevation and certainly enhances the overall feel, as far as I am concerned."

Richard Davies,
Head of Estates at Parc Noyadd



Drainage Solutions - Outlets

Our Elite range of aluminium roof and balcony drainage outlets are compatible with all waterproofing membranes and build-ups.

- Unrivalled flow performance
- Saves on project costs by reducing overall downpipe numbers
- Prevents cold bridging
- Unique and reliable clamping feature
- Simple and fast installation
- Anti-Vortex dome grate available
- Accompanying online roof drainage design software

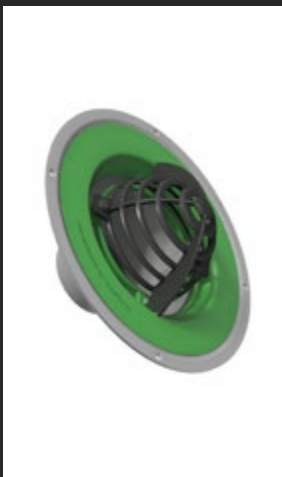

ROOF OUTLETS

- Available in 82mmØ, 110mmØ and 160mmØ pipe connection
- Supplied with a PVCu pipe connector
- Choice of dome, flat or extended grate
- Alutec's SC101 sealant required to seal the supplied PVCu threaded pipe connector to the underside of an outlet
- 2 working days delivery
- Range of accessories and spares available



PARAPET OUTLETS

- Available in 110mmØ pipe connection
- Supplied with threaded adaptor
- Parapet chutes and horizontal parapet overflow outlets available to order
- Alutec's SC101 sealant is required to seal the joints
- 2 working days delivery
- Range of accessories and spares available



BALCONY OUTLETS

- Available in 72x72mm, 76mmØ, 82mmØ and 110mmØ pipe connection
- Choice of flat or terrace grate assembled
- Balcony outlets and shallow balcony outlets with vertical spigot available to order
- Alutec's SC101 sealant is required to seal the joints
- 2 working days delivery
- Range of accessories and spares available



CAR PARK OUTLETS

- Available in 82mmØ, 110mmØ and 160mmØ pipe connection
- Supplied with a PVCu pipe connector
- Alutec's SC101 sealant required to seal the supplied PVCu threaded pipe connector to the underside of an outlet
- 2 working days delivery
- Range of accessories and spares available

Leicester's Centre for Medicine



Leicester



SNAPSHOT

The £42 million Passivhaus and BREEAM Certificate of Excellence holding Centre for Medicine built for The University of Leicester comprises three towers of differing heights linked by glass-roofed atria. Whilst visually stunning, the building posed a significant rainwater drainage challenge, therefore complex calculations and bespoke components had to be made to cope with the cascading run-off.

THE SOLUTION

As a medical building, the roof drainage design specification for the Centre for Medicine had to meet what is known as Category 3 standard, which dictates that rainwater systems must have capacity for extremely high levels of rainfall. When combined with the unusual roof structure of the building, this meant that Alutec had to design and develop specially wide and long rainwater chutes which included roof membrane clamping flanges and which penetrated the complex parapet wall configuration.

Purpose made hoppers and downpipes were also required to suit. In addition, some of the rainwater pipework intended to be run internally had to be diverted to drain outside the building before transferring to internal drainage, something which was not originally intended. Alutec worked very closely with the architects and roofing contractor, providing all flow calculations and matrices for the complicated cascading roof system.

AT A GLANCE

Products:

- Bespoke Parapet Chutes System
- Bespoke Hopper System
- Bespoke Downpipe System

Market sector:

Healthcare

Architect:

Associated Architects Birmingham

Contractors:

Willmott Dixon
IKO

Installer:

BriggsAmasco

"The high level of specification on this project demanded the best quality products and high-quality workmanship. As the main roofing contractor responsible for the waterproofing, capping, green roof and rainwater system installation, we were in constant communication with Alutec's technical department and the architects.

Duncan Philbin, Project Supervisor at BriggsAmasco



New London development



Lea Bridge Road in Walthamstow



SNAPSHOT

Alutec has designed and supplied bespoke balcony outlets for a £30 million London development on Lea Bridge Road, known as Motion, in Walthamstow. Alutec was specified for its high quality, cost effective aluminium outlets which, due to design requirements, were adapted to enable the concealment of pipe fixings and accept square downpipes telescopically.

Designed by Pollard Thomas Edwards and built by Hill in partnership with London property developer Peabody, the flagship scheme comprises nine residential blocks of up to 18 storeys in height, offering 300 residential apartments – including 62 affordable properties.

THE SOLUTION

Square downpipes were chosen to fit in with the angled aesthetic of the façade and concealed pipe fixings, one in the soffit void by means of a spigot and the other under the balcony decking, were used as an alternative to securing the downpipes to the façade itself. This solution has ensured that the integrity and aesthetic of the façade has been maintained.

Early collaboration on the project meant that Alutec was able to adapt its roof outlets to suit the needs of the project.

AT A GLANCE

Products:

- Balcony Outlets System
- Bespoke Pipe Fixings
- Bespoke Spigot Solution

Market sector:

Private Housing

Client:

Green Consultancy

Architect:

Pollard Thomas Edwards

Contractor:

Hill Partnerships

Merchant:

Travis Perkins

“To create a solution, Alutec designed the welded square spigot and produced it offsite to the required length and profile. By adapting the products in their factory, Alutec saved us significant time on site when compared to a traditional on-site adaption. The result is very tidy with no visible fixings and the help we received from the Alutec team was excellent. They even created unique product codes for the outlets and inputted them on the schedule of works which all contributed towards a smooth installation.”

Evan Waters, Senior Contract Surveyor at Hill Partnerships



Rainwater Solutions

Roof Drainage Design

DESIGN BASIS

Alutec gutter flow capacities shown on pages 54-55 in the flow capacity table are calculated with the gutters being fixed nominally level. Most metal gutters are installed level for aesthetic purposes. However, if installed to a fall of 1:600 the flow capacity will be marginally improved.

Factors to be considered when designing an eaves drainage system.

1. Rainfall intensity design rate (l/s/m²).
2. Effective roof area (ERA) to be drained (m²).
3. Gutter flow capacity (l/s).
4. Size, number and position of outlets.
5. Frictional resistances in long gutter runs and the number of corners.



To assist designers and specifiers we have produced an online rainwater design calculator. The tool guides the user step by step allowing fast and simple roof drainage design whilst ensuring full compliance with BS EN 12056-3 rainwater drainage design standard. Upon completion, a full set of calculations are produced, confirming product suitability.

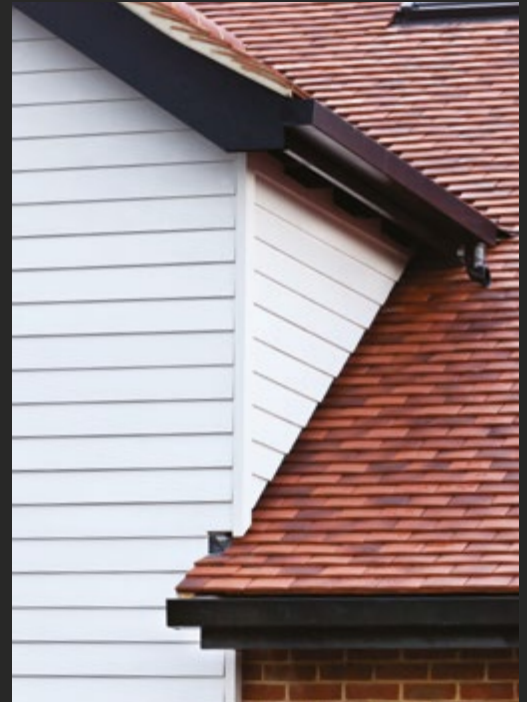

RAINFALL INTENSITY DESIGN RATE

Building Regulations 2000 Document H3 recommend a general design rate of 0.021 l/s/m² (which is virtually the same as the traditional design rate of 75mm/hour) for eaves gutters where if overflowing occurs, water overspill will discharge clear of the building without risk of water ingress.

If required, alternative rainfall intensity design rates can also be considered. Meteorological data published in the National Annex to EN12056 and Building Regulations 2000 Document H3, show varying rainfall intensities throughout the UK depending on geographical location.

The flow capacities table (page 32) indicates maximum flow, the gutter being full to the brim, however EN12056 states the design rate run-off from the roof should not exceed 90% of the gutter capacity. Also shown are the differences between outlet capacities when positioned centrally or at the end of a gutter run.

EFFECTIVE ROOF AREA

Effective roof area can be determined by calculation as set out in EN12056-3.

The following example shows a basic calculation method that can be used as a guide in establishing the effective roof area (ERA).

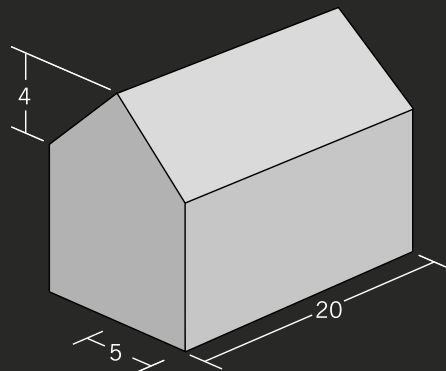

$$ERA = \left(\frac{4}{2} + 5 \right) \times 20 = 140m^2$$

GUTTER CAPACITY

Assuming the recommended rainfall intensity of 0.021 l/s/m² is acceptable, determine if the gutter outlet is to be positioned centrally, or at the end of the gutter run. Refer to the flow capacities table (pages 54 and 55) and find the nearest roof area m² in either the 'central' or 'end outlet' options to determine the size/type of gutter/rainwater pipes required.

Should a different rainfall intensity design rate be required, multiply the alternative design rate by the ERA to establish the required gutter capacity (l/s). Then refer to the flow capacities table and select the nearest gutter flow capacity (l/s). Ensure that appropriate proportional allowances for central or end of gutter outlets are made.

Example:

Alternative design rate
0.025 l/s/m² × 140m² = 3.5 l/s

3.5 l/s into centre outlet =
Aligator® Ogee No. 46
with 63mm Ø outlet

Use our online roof drainage design calculators at
marleyalutec.co.uk/calculators

Rainwater Solutions

Technical Advice



FRictional RESISTANCES

Gutter Angles: EN12056-3 recommends that the gutter capacity should be reduced by a factor of 0.85 if the gutter run includes one or more angles greater than 10 degrees and that positioning of outlets adjacent to angles should be avoided.

Long Gutters: Frictional resistance in very long gutter runs will effectively reduce the flow capacity, hence reduction factors should be applied in accordance with recommendations detailed in EN12056-3.

Valley Discharges: Where a discharge from long valley occurs, it is prudent to consider a corner hopper or purpose made gutter angle with larger catchment area, to cope with the concentrated volume of rainwater during storm conditions.

COMPATIBILITY

To avoid bi-metallic corrosion, ensure electrolytically incompatible materials do not come in direct contact with un-insulated plain aluminium surfaces. In particular ensure that the recommended compatible screws and fixings are used. Polyester powder coated surfaces will give limited protection, but should not be solely relied upon.

If in doubt, please contact the Alutec Technical Services Department.

DURABILITY

Alutec systems are manufactured from marine grade aluminium and under normal UK atmospheric conditions, Alutec systems if correctly installed have a functional life expectancy of 50 years or more, with minimal maintenance. The life expectancy is likely to be reduced in environmentally aggressive areas.

CHEMICAL

All products are naturally corrosion resistant under normal atmospheric conditions. Not to be used for chemical drainage or in conjunction with foul waste drainage.

FIRE

In general Alutec rainwater products do not aid combustion and are rated as follows

FINISH RATING	TEST STANDARD
Plain finish – non combustibility	BS 476: Part 4
PPC – 0.1 fire propagation index	BS 476: Part 6
PPC class 1, flame surface spread	BS 476: Part 7

THERMAL

Coefficient for thermal expansion – 0.000026 deg C for cast aluminium and 0.000023 deg C for sheet and extruded aluminium. Melting point approximately 660 deg C.

Rainwater Solutions

Non Standard Requirements

To accommodate unusual curves or angles, roofs which intersect at different levels or any other feature of an installation not covered by the standard ranges, Alutec offer a bespoke product service to complement any non standard requirements.

An indication of the most common non standard items are shown below, however other items may be possible. For further advice, contact the Alutec Technical Services department.

TRUE RADIUSED GUTTERS

True radiused gutters can be sand cast to simulate all profiles in the Alutec range. Sand casting involves making a wooden pattern of the gutter profile, to the given radius, from which the sand moulds are made. In view of the pattern cost, this method can be costly for small quantities.

Due to building and foundry tolerances, it is recommended that radiused gutters are made in approximately 1m lengths.



True Radius

SEGMENTED RADIUSED GUTTERS

Achieved by internally welding together segments of machine mitred gutter to achieve a given radius. Dependent on the radius, the more segments introduced the better the appearance.

This method is less expensive than sand casting and in general the segmentation is not easily noticeable on two storey buildings and above.



Segmented Radius



SITE DIMENSIONS

As theoretical radius dimensions are often subject to extreme building tolerances, we recommend that a rigid 1m long radiused template be cut or marked on site. The template should be offered up to the fascia at 1m intervals to check the fascia has been constructed to a uniform radius. The template should be sent to Alutec Technical Services Department for use as a master template.



COMPOUND GUTTER ANGLES

Any reasonable degree of angle can be fabricated. However, care must be taken in establishing accurate site dimensions and degrees of angle. Experience has proved that theoretical geometry may not be accurate, hence each angle should be site checked and location referenced.

SPECIAL ADAPTORS

Adaptors between different sized rainwater pipes or drain connections can be fabricated to customer requirements, subject to design criteria. Accurate dimensional details are required.

SPECIAL GUTTER OUTLETS

Standard gutter outlets can be modified to customer requirements subject to design criteria. However it should be noted that this may be detrimental to the flow performance of that outlet.

SPECIAL PIPE AND GUTTER BRACKETS

Special support brackets for use in conjunction with standard or bespoke products are available to order subject to design criteria.

LIGHTNING CONDUCTOR LINKS

To determine if lightning links are required, it is recommended you consult with a specialist Lightning Protection Consultant or Installer.

BESPOKE HOPPER HEADS

Individually designed hoppers can be fabricated from sheet aluminium and a variety of decorative cast motifs and embellishments can be added to enhance the appearance, if required.

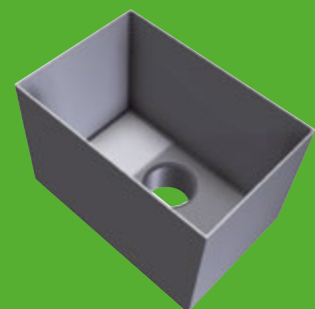





Gutters Flow Capacity

Gutter flow rates







GUTTER PROFILE		DOWNSPIPE SIZE	END OUTLET		CENTRE OUTLET	
			Capacity l/s	Effective Roof Area m ²	Capacity l/s	Effective Roof Area m ²
Half Round 123x51mm		63mm Ø	0.85	41	1.8	87
Deepflow 128x75mm		76mm Ø	2.5	120	4.9	232
Box 130x85mm		76mm Ø	3.0	142	6.0	286
		72x72mm	3.5	167	7.0	333
Ogee 130x95mm		76mm Ø	3.0	142	6.0	286
		72x72mm	3.5	167	7.0	333

Gutter flow rates

GUTTER PROFILE		DOWNSPIPE SIZE	END OUTLET		CENTRE OUTLET	
			Capacity l/s	Effective Roof Area m ²	Capacity l/s	Effective Roof Area m ²
100mm Half Round		63mmØ, 76mmØ, 72x72mm	0.70	33	1.40	66
113mm		63mmØ, 76mmØ, 72x72mm	0.85	40	1.70	80
125mm		63mmØ, 76mmØ, 102mmØ, 72x72mm, 102x76mm	1.27	60	2.54	120
100mm Victorian Ogee		63mmØ, 76mmØ, 72x72mm	0.54	25	1.08	51
113mm		63mm Ø	0.62	29	1.20	57
125mm		76mm Ø, 72x72mm	0.62	29	1.24	59
		63mm Ø	0.75	35	1.60	76
100mm Moulded Ogee		76mm Ø, 72x72mm, 102x76mm	0.80	38	1.70	80
		63mmØ, 76mmØ, 72x72mm, 102x76mm	1.15	55	2.25	108
		63mm Ø	2.21	105	3.77	179
		76mm Ø	2.21	105	3.77	179
		102mm Ø	2.21	105	4.48	213
		72x72mm	2.21	105	3.53	168
		102x76mm	2.21	105	4.49	213
		102x102mm	2.21	105	4.51	214
150mm		63mm Ø	2.75	131	4.90	236
		76mm Ø	2.75	131	4.90	236
		102mm Ø	2.75	131	5.50	263
		72x72mm	2.75	131	3.60	174
		102x76mm	2.75	131	5.47	263
		102x102mm	2.75	131	5.47	263

Gutters Flow Capacity

aligator Gutter flow rates

GUTTER PROFILE		DOWNSPIPE SIZE	END OUTLET		CENTRE OUTLET	
			Capacity l/s	Effective Roof Area m ²	Capacity l/s	Effective Roof Area m ²
Aligator® Classic 120x75mm		63mm Ø	2.15	102	4.13	196
		76mm Ø	2.15	102	4.13	196
		72x72mm	2.15	102	4.13	196
Aligator® Deepflow 130x80mm		63mm Ø, 76mm Ø	2.10	100	4.00	190
		102mm Ø, 72x72mm	2.20	104	4.20	200
		102x76mm	2.20	104	4.20	200
Aligator® Ogee No. 46 155x100mm		63mm Ø	3.50	166	5.90	280
		76mm Ø	3.80	180	5.90	280
		102mm Ø	4.00	190	7.60	361
		72x72mm, 102x76mm	3.90	185	7.50	357
		102x102mm	4.10	195	7.60	361
Aligator® Boxer 120x80mm		63mm Ø	2.27	108	3.39	161
		76mm Ø	2.27	108	3.75	178
		72x72mm	2.27	108	4.26	202
		102x76mm	2.27	108	4.34	206
Aligator® Boxer 135x100mm		63mm Ø	4.17	198	4.17	198
		76mm Ø	4.38	208	5.92	281
		102mm Ø	4.38	208	5.97	284
		72x72mm	4.38	208	6.49	309
		102x76mm	4.38	208	7.09	337
		102x102mm	4.38	208	7.14	340
Aligator® Boxer 160x100mm		63mm Ø	4.22	200	4.22	200
		76mm Ø	5.25	249	6.06	288
		102mm Ø	5.25	249	6.11	290
		72x72mm	5.25	249	6.68	318
		102x76mm	5.25	249	7.35	350
		102x102mm	5.25	249	7.41	352
Aligator® Giant 200x150mm		76mm Ø	7.84	373	8.67	412
		102mm Ø	7.91	376	8.75	416
		72x72mm	7.92	377	9.59	456
		102x76mm	7.92	377	10.60	504
		102x102mm	7.92	377	10.76	512

Hopper Heads Flow Capacity

HOPPER HEADS	DOWNPIPE SIZE	CAPACITY, L/S
Standard	63mmØ	3.01
	76mmØ	4.46
	102mmØ	7.94
	72x72mm	4.37
	102x76mm	7.17
	102x102mm	9.49
Fluted	63mmØ	3.01
	76mmØ	4.46
	72x72mm	4.37
Ornamental	63mmØ	3.01
	76mmØ	4.46
	102mmØ	7.94
	72x72mm	4.37
	102x76mm	7.17
	102x102mm	9.49
Contemporary Standard	63mmØ	3.5
	76mmØ	5.1
	102mmØ	9.3
	72x72mm	5.8
	102x76mm	8.6
	102x102mm	11.6
Contemporary Large	63mmØ	3.8
	76mmØ	5.5
	102mmØ	10
	72x72mm	6.2
	102x76mm	9.3
	102x102mm	12.5
Contemporary Extended	63mmØ	4.3
	76mmØ	6.2
	102mmØ	11.2
	72x72mm	7
	102x76mm	10.5
	102x102mm	14.1

NON-STANDARD HOPPERS

Individually designed hoppers can be fabricated from sheet aluminium and a variety of decorative cast motifs and embellishments can be added to enhance the appearance if required.



Eaves Solutions

Technical advice for installation of fascia and soffit

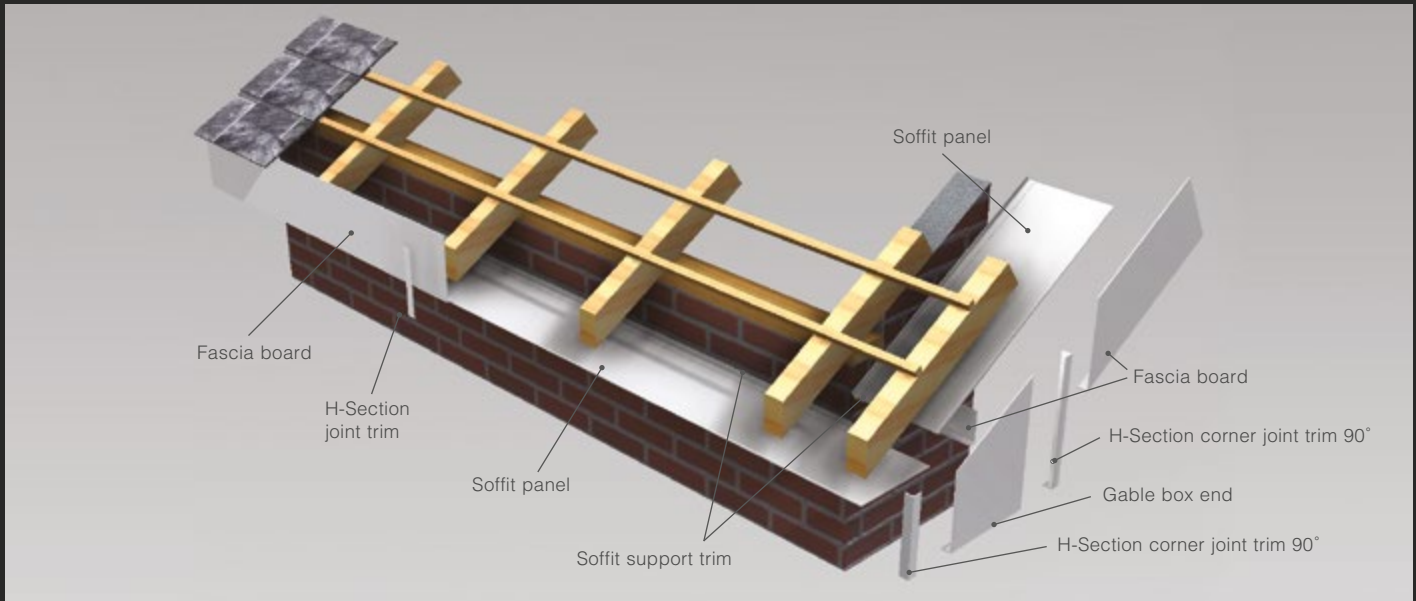

EVOKE INSTALLATION

Full installation instructions are provided with each delivery and can also be downloaded from www.marleyalutec.co.uk



CUTTING

Cut, drill and fix using standard wood working tools. De-burr edges after cutting.



FORMING & BENDING

Small pieces can be bent on site by grooving the rear face with a router, then bending the material upwards to the required angle.



For detailed information, refer to the full Evoke installation instructions.



FIXING FASCIA & SOFFIT

Evoke fascia and soffit panels can be either mechanical fixed with Alutec polytop annular nails or bonded with Sikatack® - Panel System.

JOINT ABUTMENTS

Joint abutments can be covered with a H-Section Joint trim or the 4mm expansion gap can be neatly pointed with colour matched Joint sealant SC103 to give a shadow gap appearance.

FIXING GUTTERS

Gutters can be fixed directly to Evoke fascia panels without the requirement of a backing board.



COMPATIBILITY

Evoke aluminium composite sheet is compatible with most building materials, with the exception of direct or indirect contact with copper or direct contact with zinc onto unpainted surfaces of the aluminium facing. If fixing to zinc or galvanized surfaces, it is recommended that an isolative membrane is fitted between touching surfaces. Aluminium composite is resistant to alkali, acids and salt spray corrosion, hence ideal for installation in a marine environment. For further guidance please contact the Alutec Technical Services Department.

Eaves Solutions

Technical advice for roof condensation and ventilation BS 5250

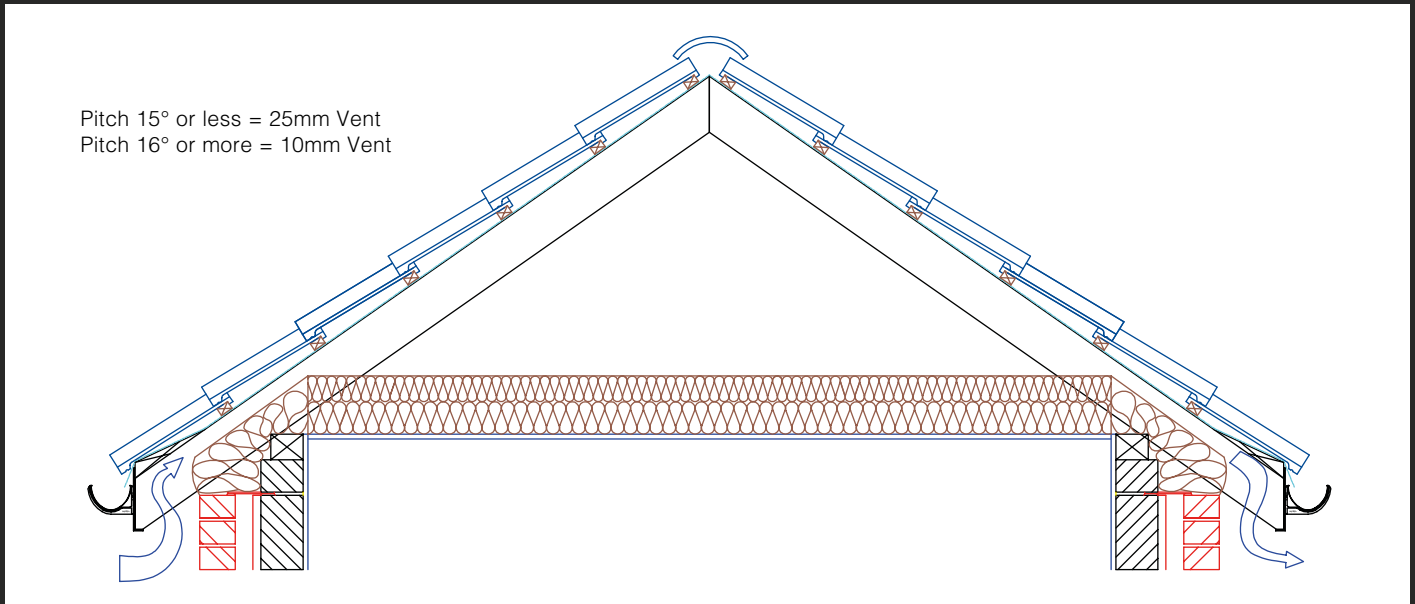

COLD ROOFS

Roofs with a large void above the insulation where insulation is at ceiling level and the void is therefore uninhabited and cold.

- 25mm along the length of the eaves for pitches of 15° or less
- 10mm along the length of the eaves for pitches of more than 15°

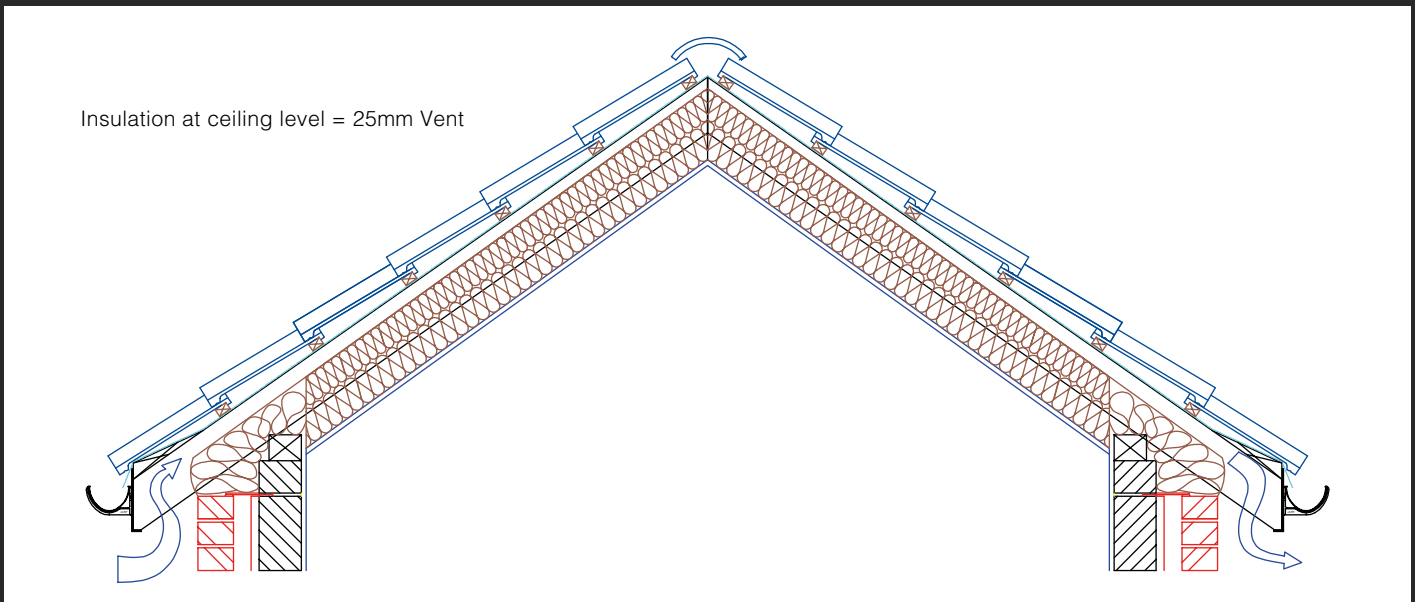

WARM ROOFS

Roofs with no void above the insulation where the insulation follows the line of the rafters, often creating a habitable space, or warm roof.

- Low level openings should be equivalent in area to a continuous opening of not less than 25mm along the length of all the eaves

Eaves Solutions

Bespoke design service for fascia and soffit

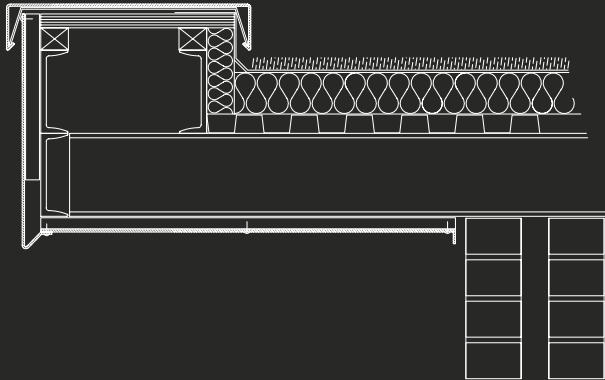

Alutec's experienced Technical Design team is on hand from initial design stage through to completion to ensure the designers' concepts are met. Alutec are on hand to advise on correct, cost effective system application, whilst maintaining the intended visual impact of the design.

Alutec has full 2D and 3D CAD capability to keep communication simple and easy in the exchange of ideas. When the design has been finalised, we produce manufacturing drawings for client approval prior to site installation. At final installation stage we will then work with the installers to ensure a smooth installation process.

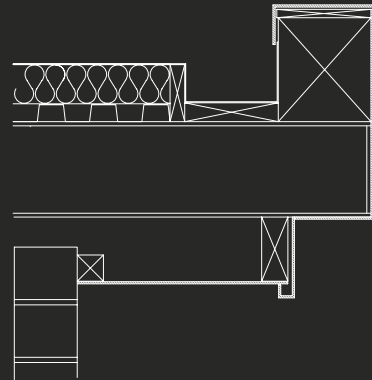

Bespoke design service for coping system

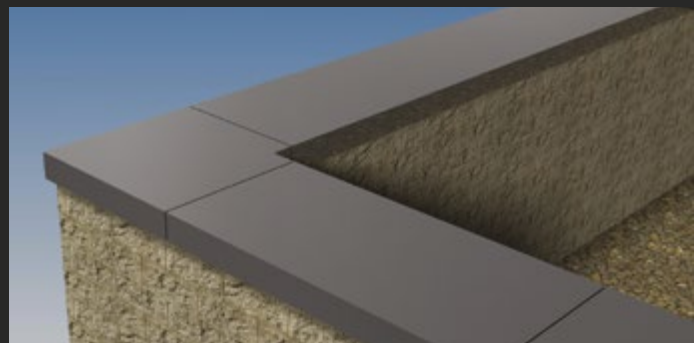
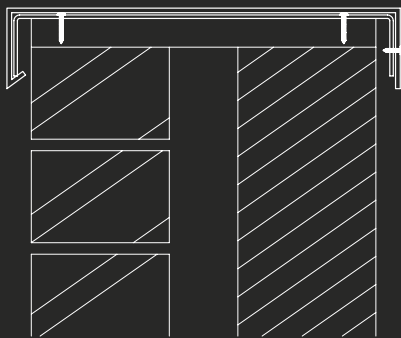

Every project is different, so Alutec works with each client to ensure optimum performance of the system is achieved and costs kept to a minimum, whilst maintaining the clients' intended design and

visual impact. Once designs are agreed, we produce manufacturing drawings for client approval. Support is available to installers upon request to ensure a smooth installation process.

Drainage Solutions

Technical advice



Alutec has developed a revolutionary range of aluminium roof and balcony drainage outlets compatible with all waterproofing membranes and roof build-ups.

Elite rainwater drainage outlets, together with ancillary components, are suitable for use with bituminous, hot melt, GRP, single ply, asphalt and cold liquid applied membranes to:

- Cold roofs
- Warm roofs
- Inverted roofs
- Green roofs
- Terraces
- Balconies
- Podiums
- Walkways
- Paved areas
- Car parks

UNBEATABLE DRAINAGE FLOW PERFORMANCE

Elite outlets have been engineered for unbeatable drainage flow performance and in most cases are only restricted by the maximum allowed water capacity of the connecting pipework!

SAVE ON PROJECT COSTS BY REDUCING RAINWATER PIPE REQUIREMENTS

Compared to many conventional outlets, Elite performance figures reduce the number of outlets required to drain an area, thereby reducing the rainwater pipe and underground drainage requirements, offering significant savings.

OPTIMUM WATERTIGHT SEAL

Elite outlets membrane compression clamp design, combined with a high-performance butyl sealing ring, securely lock the waterproof membrane to the outlet body ensuring a durable watertight seal.

SUSTAINABLE MATERIAL WITH 50 YEAR LIFE EXPECTANCY

All outlet components are manufactured from marine grade aluminium to give an extensive life expectancy of at least 50 years. Aluminium is well known for its durable characteristics and will never corrode or degrade. Marine grade aluminium, together with the 304 grade stainless steel fixings, ensures compatibility and durability.

TESTED TO EXTREMES!

Typically, within roof drainage design, the peak rainwater design depth at an outlet will not exceed 35mm. To ensure ultimate reliability and confidence, the Elite outlet range has been rigorously tested to withstand water depths surpassing 1m.

PREVENTS COLD BRIDGING

The Elite range incorporates PVCu pipe connectors, providing an air tight seal and thermal break between the outlet body and connecting pipework.

CONNECTS TO ALL COMMON PIPE SIZES

Our roof outlet range connects to all common PVCu, HDPE and socketless cast iron pipework sizes.

Balcony outlets connect to aluminium (76mmØ & 72x72mm), PVCu (82mmØ & 110mmØ) and socketless cast iron (70mmØ & 100mmØ) pipework.

FIRE PROTECTION

The threaded PVCu pipe connectors are manufactured from BS EN 1329 pipework and are therefore suitable for use with pipe wraps and fire collars.

THERMAL BREAK AND FIRE SAFETY

Our Elite range of parapet outlets incorporate PVCu threaded pipe connectors which provide a thermal break between cavity walls. The thermal break prevents moisture droplets from forming on the outlet spigots, within the cavity, causing hard to detect damp issues. It is also worth noting that thermal breaks are excluded from the Fire Safety: Approved Document B which means our outlets are suitable for use at all building heights.

Drainage Solutions

Technical Information on Drainage Design

Roof drainage design

ONLINE DESIGN TOOL

The Elite range comes complete with an online drainage design tool, in full compliance with BS EN12056-3, allowing fast and simple drainage design whilst ensuring correct product specification.

www.marleyalutec.co.uk



The tool provides the user with a full set of drainage calculations to confirm suitability of product along with links to detailed product specific information. Our Technical Services department are also on hand to assist with any drainage design queries. Contact tel: 01234 359438.



Practical design recommendations

RAINWATER OUTLET POSITIONING

Outlets should be distributed as evenly as possible throughout the roof areas in order to accept an equal proportion of the rainwater runoff.

EMERGENCY OUTLETS/OVERFLOWS

Overflows should be included within the design of all flat roofs and balconies with perimeter upstands greater than 50mm. Overflows indicate if there is a maintenance requirement and prevent rainwater over spilling into the building's fabric or causing structural overloading.

ACCESSIBILITY

All outlets should be clearly identifiable and accessible for maintenance. Outlet gratings should not be covered over by pavers, decking, plant material, ballast etc.

MAINTENANCE

For optimum performance, ensure roof outlets are inspected and cleaned every six months to ensure peak operation.

PIPEWORK

Our rainwater outlet maximum performance figures, in many cases, are restricted by the maximum allowed capacity of the connecting pipe system. If it is intended to link multiple roof outlets within a singular pipework run, the combined capacity of the outlets must not exceed the design capacity of the pipe system.

BALCONY OUTLET PIPEWORK

To reduce the risk of a balcony outlet becoming overwhelmed in a storm event, it is good practice to connect each balcony outlet separately into a continuous main rainwater pipe drop, as opposed to draining balconies from above onto lower. If a continuous main rainwater pipe drop is not an option, rainwater outlets and overflows need to be suitably sized to accept the total combined drainage from the above balconies at each level.

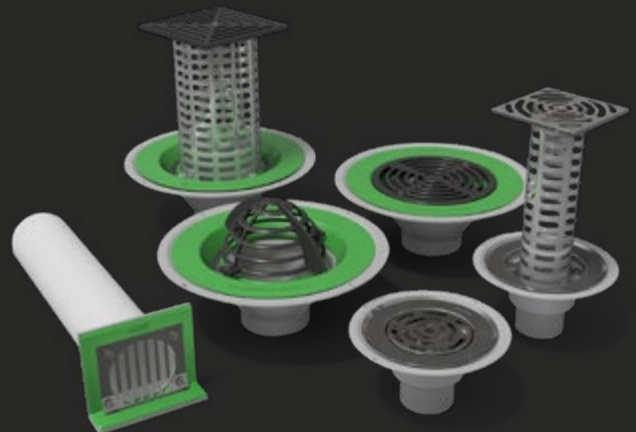

General Information

Alutec Product Conformity Statement



Alutec aluminium rainwater systems have a functional life-expectancy of 50+ years with minimal maintenance. All products are manufactured using only marine grade aluminium and coated with external grade architectural powders.

MATERIAL GRADES

- Castings: LM6 grade
- Extrusions: 6063 T5 grade

STANDARDS TO WHICH WE COMPLY AND EXCEED:

Testing:

- BS EN ISO 9227:2012 – Corrosion tests in artificial atmospheres. Salt spray tests.
- BS EN 1462:2004 - Brackets for eaves gutters. Requirements and testing.
- BS EN 12056-3:2000 - Gravity drainage systems inside buildings. Roof drainage, layout and calculation.
- BRE - Wind load testing (Coping)
- CRM - Accelerated thermal movement joint test (Gutters)
- CRM – Roof gully drainage capacities (Roof outlets)

Fire ratings:

- BS 476-6 Class 0 – Contribution to the growth of fire (Evoke fascia and soffit)
- BS476-7 Class 1 – Surface spread of flame (Evoke fascia and soffit)
- EN 13501-1 – A2-s1,d0 (Polyester powder coated aluminium products)
- EN 13501-1 – B-s1,d0 (Evoke fascia and soffit)
- BS476 – Non-combustible materials (Gutters, pipes and copings)

Manufacture:

- BS EN 755-2:2013 – Aluminium and aluminium alloys. Extruded rod/bar, tube and profiles. Mechanical properties.
- BS EN 12020-2:2008 - Aluminium and aluminium alloys. Extruded precision profiles in alloys EN AW-6060 and EN AW-6063. Tolerances on dimensions and form.
- BS EN 1706:2010 - Aluminium and aluminium alloys. Castings. Chemical composition and mechanical properties.
- BS EN 1559-2:2014 – Founding. Technical conditions of delivery.
- BS EN 515:1993 - Aluminium and aluminium alloys. Wrought products. Temper designations.
- BS EN 573-3:2013 - Aluminium and aluminium alloys. Chemical composition and form of wrought products. Chemical composition and form of products.
- BS EN 485-2:2013 - Aluminium and aluminium alloys. Sheet, strip and plate. Mechanical properties.
- BS 8530:2010 - Traditional-style half round, beaded half round, Victorian ogee and moulded ogee aluminium rainwater systems. Specification.
- BS EN 12056-3:2000 - Gravity drainage systems inside buildings. Roof drainage, layout and calculation.
- BS EN 1253-2: 2002 – Roof drains and gullies without trap

ACCREDITATION

ISO 14001 – Environmental management systems

CE MARKING

CE Marking is not a requirement for gutters and associated products. However, Alutec have 2 products in their product range which comply with the requirement of harmonised European standards (hENs) – Alutec Silicone sealants, product codes SC101 and SC103. The Declarations of Performance (DoP) are available on request or to download from our website.

General Information

Alutec Product Life Expectancy, Maintenance and Warranties Statement

PRODUCT LIFE EXPECTANCY

The life expectancy of any external building product, including Alutec systems will vary depending on frequency of maintenance and its location (i.e. local pollution levels or marine environments).

Based on test data and knowledge gained from previous projects, Alutec systems have a functional life expectancy of 50 years or more, all products are manufactured using only marine grade aluminium (extrusions – 6000 series and Castings - LM6).

Our polyester powder coatings are architectural grade, which are specifically designed for external use ensuring long-term colour stability. Our powder coatings have a 25 year plus decorative life expectancy; however, our maintenance recommendations must be strictly followed.

To ensure maximum durability, it is essential that all Alutec systems are installed and maintained in accordance with our recommendations.

PRODUCT MAINTENANCE

Inspection:

It is good practice to carry out product inspections at least annually throughout the lifetime of the building. Inspect rainwater systems for any accumulation of debris and coated surfaces for any damage, grime or mould build up. Changes in the paint condition are more likely to occur towards the end of the paint life, which would be the time to consider re-painting the products.

Decorative coatings:

In order to meet the 25-year decorative life expectancy of the coated aluminium products, it is important that the building is inspected and maintained at least annually or every 6 months in a marine environment.

Factors affecting the life of the decorative finishes:

- Proximity to marine and coastal conditions i.e. exposure to salt water
- Proximity to local pollutants and emissions from industrial, traffic and oil-fired plants
- Solar radiation – the sun affects the coating by ultraviolet radiation and heat
- Colour selected i.e. light colours last longer than dark colours
- Damage including handling and impact
- Exposure to harmful and corrosive substances
- Exposure to plant or tree resins
- Lack of or insufficient inspection, maintenance and washing



MAINTENANCE:

Washing

Rainwater alone is often sufficient to keep exterior surfaces looking clean and bright. However, in order to maximise the lifetime of the organic coated product, it is important that accumulated dirt and debris that has not been washed away by normal rainfall should be removed by cleaning. This reduces the risk of 'poultice' corrosion of the base material. Washing may be carried out with a hose and soft bristle brush, using fresh water. In areas where heavy industrial deposits dull the surface, a solution of fresh water and household detergent may be applied to ensure a thorough clean. For household detergent use a 10% solution. Always rinse thoroughly with clean water.

Paint repair

If lightly scuffed it is better to leave the surface of the organic coating rather than treat. If, however scratched through to the bare metal the damage can easily be repaired by applying standard touch up paint. The applied paint area should be no wider than the original scratch and to achieve this we recommend using a medium to fine artist paint brush. If the area is excessively damaged replacement parts should be considered.

Gutter checks

Gutters should be periodically cleaned out and any built up debris removed to maintain peak performance. Check for any leaks and that all fixings are secure. Take any remedial action necessary to rectify.

Gutter Joint repair

Separate and remove the joint components. Make sure all existing silicone sealant is removed from the joint before applying new. This can be carried out using silicone removal paste and a flat blade. If the joint components have been damaged in anyway during removal replace the items with new. Create new joint seals as instructed within our installation guides.

GUARANTEES AND WARRANTIES

Alutec does not issue specific paper guarantees or warranties for any of its building products as the life expectancy will vary depending on frequency of maintenance and its installation location (i.e. local pollution levels, marine environments, high UV). However, all Alutec products are produced in strict accordance with the relevant BS/ EN standards, are stringently tested prior to entry into the market and there after manufactured in accordance with internationally recognised quality standards.

In the unlikely event of a design or manufacturing deficiency with a Alutec product, we would always respond in a responsible manner, as would be expected of an established well-respected company. Therefore, you can rest assured that in the unlikely event of a product failure, Alutec will honour its obligations under its corporate products liability insurance.

With specific regard to the Alutec range of products, we publish within our Design and Installation Guides an approximate functional product life expectancy as being 50 years. The decorative life expectancy of the paint finishes is approximately 25 years.

General Information

Product Handling, Storage and Safety



Gutters and pipes should be handled with care and should preferably be stored under cover on racks to prevent scratching or denting.

All polyester powder coated gutter and pipe lengths are supplied in protective polythene sleeving and components packed in cardboard boxes.

If polyester powder coated products are stored outside, cover with a tarpaulin to guard against water ingress into the protective polythene tubing. If water becomes trapped within the polythene wrapping and left exposed to warm sunlight, it may leave permanent water stains on the paint finish.

Sealants should not be stored in temperatures below 0°C and kept away from any direct heat source. Solvent cleaners must be stored away from any direct heat or combustible source, preferably in an appropriate fire resistant storage cabinet.

Mill finished goods to be installed in their natural state should also be stored undercover, to prevent uneven oxidization to visible surfaces. Once installed the surface will mature uniformly.

Fascia, soffit and coping systems should be stored under cover to protect against ingress of water between surfaces of composite aluminium sheets. Flat panels should be stored fully supported on a flat surface. Profiled lengths should also be fully supported throughout the product length and appropriately stacked to avoid damage to the profile.

Ensure that the self-adhesive peel-off protective cover is not damaged during handling exposing the painted surface to potential damage.



SAFETY

The relevant safety regulations are outlined in the Health and Safety at Work Act 1974 and should be followed. Refer to The Approved Code of Practice (Design and Management) 2007.

Handling mill finished or polyester powder coated aluminium products does not pose any known health hazard, however it is recommended to wear protective gloves when handling mill finish aluminium.

Handling composite aluminium products do not pose any known health hazard, however it is recommended that protective gloves are worn.

Hazard instructions relating to sealant, solvent cleaner and touch up paint are printed on their respective containers and COSHH data sheets are available on the website.

Online Calculators and Tools



To help designers and specifiers we have produced a set of online tools and calculators.

Alutec Eaves Gutter System Rainwater Calculator

Alutec

Project: **ALUTEC**

Company: **ALUTEC**

Address: **ALUTEC**

City: **ALUTEC**

Country: **ALUTEC**

Postcode: **ALUTEC**

Phone: **ALUTEC**

Email: **ALUTEC**

Website: **ALUTEC**

Design Category: **ALUTEC**

Roof Pitch angle (deg): **ALUTEC**

Roof Area (sqm): **ALUTEC**

Roof Type: **ALUTEC**

Roof Slope: **ALUTEC**

Roof Material: **ALUTEC**

Roof Orientation: **ALUTEC**

Roof Elevation: **ALUTEC**

Roof Level: **ALUTEC**

Roof Height: **ALUTEC**

Roof Length: **ALUTEC**

Roof Width: **ALUTEC**

Roof Depth: **ALUTEC**

Roof Area: **ALUTEC**

Roof Volume: **ALUTEC**

Roof Weight: **ALUTEC**

Roof Load: **ALUTEC**

Roof Stress: **ALUTEC**

Roof Deflection: **ALUTEC**

Roof Vibration: **ALUTEC**

Roof Fatigue: **ALUTEC**

Roof Corrosion: **ALUTEC**

Roof Spalling: **ALUTEC**

Roof Cracking: **ALUTEC**

Roof Delamination: **ALUTEC**

Roof Peeling: **ALUTEC**

Roof Flaking: **ALUTEC**

Roof Scaling: **ALUTEC**

Roof Spalling: **ALUTEC**

Roof Cracking: **ALUTEC**

Roof Delamination: **ALUTEC**

Roof Peeling: **ALUTEC**

Roof Flaking: **ALUTEC**

Roof Scaling: **ALUTEC**

Roof Spalling: **ALUTEC**

Roof Cracking: **ALUTEC**

Roof Delamination: **ALUTEC**

Roof Peeling: **ALUTEC**

Roof Flaking: **ALUTEC**

Roof Scaling: **ALUTEC**

Gutter System Rainwater Calculator

Estimate Number ET 225 WEB

Alutec Estimate

10 January 2019

Project Title: **ALUTEC**

Project Address: **ALUTEC**

Project Reference: **ALUTEC**

Project Manager: **ALUTEC**

Project Engineer: **ALUTEC**

Project Designer: **ALUTEC**

Project Checker: **ALUTEC**

Project Approver: **ALUTEC**

Project Status: **ALUTEC**

Project Date: **ALUTEC**

Project Location: **ALUTEC**

Project Client: **ALUTEC**

Project Contact: **ALUTEC**

Project Phone: **ALUTEC**

Project Email: **ALUTEC**

Project Website: **ALUTEC**

Project Description: **ALUTEC**

Project Details: **ALUTEC**

Project Notes: **ALUTEC**

Project Comments: **ALUTEC**

Project History: **ALUTEC**

Project Changes: **ALUTEC**

Project Approvals: **ALUTEC**

Project Signatures: **ALUTEC**

Project Stamps: **ALUTEC**

Project Seals: **ALUTEC**

Project Marks: **ALUTEC**

Project Symbols: **ALUTEC**

Project Icons: **ALUTEC**

Project Images: **ALUTEC**

Project Videos: **ALUTEC**

Project Audio: **ALUTEC**

Project Documents: **ALUTEC**

Project Links: **ALUTEC**

Project References: **ALUTEC**

Project Citations: **ALUTEC**

Project Bibliography: **ALUTEC**

Project Glossary: **ALUTEC**

Project Index: **ALUTEC**

Project Table of Contents: **ALUTEC**

Project List of Figures: **ALUTEC**

Project List of Tables: **ALUTEC**

Project List of Equations: **ALUTEC**

Project List of Symbols: **ALUTEC**

Project List of Units: **ALUTEC**

Project List of Abbreviations: **ALUTEC**

Project List of Acronyms: **ALUTEC**

Project List of Initials: **ALUTEC**

Project List of Nicknames: **ALUTEC**

Project List of Surnames: **ALUTEC**

Project List of First Names: **ALUTEC**

Project List of Middle Names: **ALUTEC**

Project List of Last Names: **ALUTEC**

Project List of Full Names: **ALUTEC**

Project List of Real Names: **ALUTEC**

Project List of Legal Names: **ALUTEC**

Project List of Official Names: **ALUTEC**

Project List of Formal Names: **ALUTEC**

Project List of Informal Names: **ALUTEC**

Project List of Common Names: **ALUTEC**

Project List of Popular Names: **ALUTEC**

Project List of Well-Known Names: **ALUTEC**

Project List of Famous Names: **ALUTEC**

Project List of Notable Names: **ALUTEC**

Project List of Significant Names: **ALUTEC**

Project List of Important Names: **ALUTEC**

Project List of Key Names: **ALUTEC**

Project List of Major Names: **ALUTEC**

Project List of Primary Names: **ALUTEC**

Project List of Principal Names: **ALUTEC**

Project List of Main Names: **ALUTEC**

Project List of Central Names: **ALUTEC**

Project List of Core Names: **ALUTEC**

Project List of Fundamental Names: **ALUTEC**

Project List of Basic Names: **ALUTEC**

Project List of Elementary Names: **ALUTEC**

Project List of Simple Names: **ALUTEC**

Project List of Straightforward Names: **ALUTEC**

Project List of Direct Names: **ALUTEC**

Project List of Clear Names: **ALUTEC**

Project List of Plain Names: **ALUTEC**

Project List of Unadorned Names: **ALUTEC**

Project List of Undecorated Names: **ALUTEC**

Project List of Unembellished Names: **ALUTEC**

Project List of Unadorned Names: **ALUTEC**

Project List of Undecorated Names: **ALUTEC**

Project List of Unembellished Names: **ALUTEC**

Web Estimates

NBS Specification Document

Alutec

Project Title: **ALUTEC**

Project Address: **ALUTEC**

Project Reference: **ALUTEC**

Project Manager: **ALUTEC**

Project Engineer: **ALUTEC**

Project Designer: **ALUTEC**

Project Checker: **ALUTEC**

Project Approver: **ALUTEC**

Project Status: **ALUTEC**

Project Date: **ALUTEC**

Project Location: **ALUTEC**

Project Client: **ALUTEC**

Project Contact: **ALUTEC**

Project Phone: **ALUTEC**

Project Email: **ALUTEC**

Project Website: **ALUTEC**

Project Description: **ALUTEC**

Project Details: **ALUTEC**

Project Notes: **ALUTEC**

Project Comments: **ALUTEC**

Project History: **ALUTEC**

Project Changes: **ALUTEC**

Project Approvals: **ALUTEC**

Project Signatures: **ALUTEC**

Project Stamps: **ALUTEC**

Project Seals: **ALUTEC**

Project Marks: **ALUTEC**

Project Symbols: **ALUTEC**

Project Icons: **ALUTEC**

Project Images: **ALUTEC**

Project Videos: **ALUTEC**

Project Audio: **ALUTEC**

Project Documents: **ALUTEC**

Project Links: **ALUTEC**

Project References: **ALUTEC**

Project Citations: **ALUTEC**

Project Bibliography: **ALUTEC**

Project Glossary: **ALUTEC**

Project Index: **ALUTEC**

Project Table of Contents: **ALUTEC**

Project List of Figures: **ALUTEC**

Project List of Tables: **ALUTEC**

Project List of Equations: **ALUTEC**

Project List of Symbols: **ALUTEC**

Project List of Abbreviations: **ALUTEC**

Project List of Acronyms: **ALUTEC**

Project List of Initials: **ALUTEC**

Project List of Nicknames: **ALUTEC**

Project List of Surnames: **ALUTEC**

Project List of First Names: **ALUTEC**

Project List of Middle Names: **ALUTEC**

Project List of Last Names: **ALUTEC**

Project List of Full Names: **ALUTEC**

Project List of Real Names: **ALUTEC**

Project List of Legal Names: **ALUTEC**

Project List of Official Names: **ALUTEC**

Project List of Formal Names: **ALUTEC**

Project List of Main Names: **ALUTEC**

Project List of Central Names: **ALUTEC**

Project List of Core Names: **ALUTEC**

Project List of Fundamental Names: **ALUTEC**

Project List of Basic Names: **ALUTEC**

Project List of Elementary Names: **ALUTEC**

Project List of Simple Names: **ALUTEC**

Project List of Straightforward Names: **ALUTEC**

Project List of Direct Names: **ALUTEC**

Project List of Clear Names: **ALUTEC**

Project List of Plain Names: **ALUTEC**

Project List of Unadorned Names: **ALUTEC**

Project List of Undecorated Names: **ALUTEC**

Project List of Unembellished Names: **ALUTEC**

Project List of Unadorned Names: **ALUTEC**

Project List of Undecorated Names: **ALUTEC**

Project List of Unembellished Names: **ALUTEC**

NBS Specification Tool

Alutec flat roof rainwater drainage Calculator

Alutec

Project Title: **ALUTEC**

Project Address: **ALUTEC**

Project Reference: **ALUTEC**

Project Manager: **ALUTEC**

Project Engineer: **ALUTEC**

Project Designer: **ALUTEC**

Project Checker: **ALUTEC**

Project Approver: **ALUTEC**

Project Status: **ALUTEC**

Project Date: **ALUTEC**

Project Location: **ALUTEC**

Project Client: **ALUTEC**

Project Contact: **ALUTEC**

Project Phone: **ALUTEC**

Project Email: **ALUTEC**

Project Website: **ALUTEC**

Project Description: **ALUTEC**

Project Details: **ALUTEC**

Project Notes: **ALUTEC**

Project Comments: **ALUTEC**

Project History: **ALUTEC**

Project Changes: **ALUTEC**

Project Approvals: **ALUTEC**

Project Signatures: **ALUTEC**

Project Stamps: **ALUTEC**

Project Seals: **ALUTEC**

Project Marks: **ALUTEC**

Project Symbols: **ALUTEC**

Project Icons: **ALUTEC**

Project Images: **ALUTEC**

Project Videos: **ALUTEC**

Project Audio: **ALUTEC**

Project Documents: **ALUTEC**

Project Links: **ALUTEC**

Project References: **ALUTEC**

Project Citations: **ALUTEC**

Project Bibliography: **ALUTEC**

Project Glossary: **ALUTEC**

Project Index: **ALUTEC**

Project Table of Contents: **ALUTEC**

Project List of Figures: **ALUTEC**

Project List of Tables: **ALUTEC**

Project List of Equations: **ALUTEC**

Project List of Symbols: **ALUTEC**

Project List of Abbreviations: **ALUTEC**

Project List of Acronyms: **ALUTEC**

Project List of Initials: **ALUTEC**

Project List of Nicknames: **ALUTEC**

Project List of Surnames: **ALUTEC**

Project List of First Names: **ALUTEC**

Project List of Middle Names: **ALUTEC**

Project List of Last Names: **ALUTEC**

Project List of Full Names: **ALUTEC**

Project List of Real Names: **ALUTEC**

Project List of Legal Names: **ALUTEC**

Project List of Official Names: **ALUTEC**

Project List of Formal Names: **ALUTEC**

Project List of Main Names: **ALUTEC**

Project List of Central Names: **ALUTEC**

Project List of Core Names: **ALUTEC**

Project List of Fundamental Names: **ALUTEC**

Project List of Basic Names: **ALUTEC**

Project List of Elementary Names: **ALUTEC**

Project List of Simple Names: **ALUTEC**

Project List of Straightforward Names: **ALUTEC**

Project List of Direct Names: **ALUTEC**

Project List of Clear Names: **ALUTEC**

Project List of Plain Names: **ALUTEC**

Project List of Unadorned Names: **ALUTEC**

Project List of Undecorated Names: **ALUTEC**

Project List of Unembellished Names: **ALUTEC**

Project List of Unadorned Names: **ALUTEC**

Project List of Undecorated Names: **ALUTEC**

Project List of Unembellished Names: **ALUTEC**

Flat Roof Rainwater Drainage Calculator

RAINWATER DESIGN CALCULATORS

Our online tools have been designed with simplicity in mind removing the need for any prior specialist industry knowledge. The tools guide the user step by step allowing fast and simple roof drainage design whilst ensuring full compliance with BS EN12056-3 rainwater drainage design standard. Upon completion, a full set of rainwater drainage design calculations are provided confirming the suitability of products.

ESTIMATING TOOL

This produces instant list value estimates for all your Alutec product requirements. The estimate produced will be calculated at our list prices – merchant discounts will apply to all of the results.

PRODUCT SPECIFICATION TOOL

This produces specification documents for a wide range of aluminium rainwater and eaves products.

These tools can be found at www.marleyalutec.co.uk/calculators

TECHNICAL SUPPORT

Alutec's Technical Services team has many years' experience in helping specifiers with correct systems choice, roof drainage design, flow rate calculations and installation advice.

Our Technical Team can be contacted on **01234 359438**.

Contacts



ESTIMATE REQUESTS AND PRICE ENQUIRIES

Email: projects@marleyalutec.co.uk Tel: 01234 359438

ORDER PLACEMENT

Email: orders@marleyalutec.co.uk Tel: 01234 359438

Fax: 01234 357199

ORDER PROGRESSION

Tel: 01234 359438

TECHNICAL ENQUIRIES

Email: technical@marleyalutec.co.uk Tel: 01234 344108

FREE ESTIMATING TOOL

Available online at www.marleyalutec.co.uk/calculators

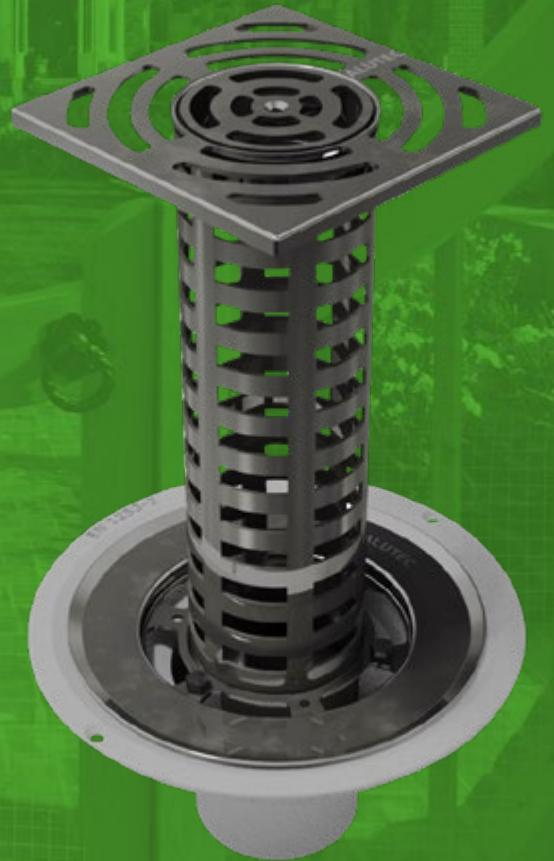

ALUTEC
ALUMINIUM RAINWATER SYSTEMS

HEAD OFFICE

For general enquiries, please call **01234 359438**

For technical enquiries please call **01234 344108**

Email: projects@marleyalutec.co.uk

Fax: **01234 357199**

Unit 1 (G-H), Viking Industrial Park, Hudson Road, Elms
Farm Industrial Estate, Bedford MK41 0LZ

aliaxis

 /marleyalutec

 @marleyalutec

 /company/marley-alutec

www.marleyalutec.co.uk